

Instruction Manual

ACW Pallet Truck with Scale



Note: Owner/Operator must read and understand this instruction manual before using the pallet truck with scale.

Thank you for using this hand pallet truck with scale. For your safety and correct operation of the scale, please read these instructions carefully before using it.

NOTE: (1) All of the information reported herein is based on data available at the moment of printing. The factory reserves the right to modify its own products at any moment without notice and incurring any sanction. So it is suggested to always verify possible updates.

(2) Prior to use this hand pallet truck with scale, the battery of scale must be charged enough.

1. GENERAL SPECIFICATIONS

Model	Capacity	Graduation	Weighing Accuracy	Fork size		
				Length	Width over forks	Fork Width
ACW20S	2000 kg	0.5 kg	± 0.05%	1150mm	542mm	162mm
ACW20L	2000 kg	0.5 kg	± 0.05%	1220mm	687mm	162mm

Materials and specifications are subject to change without notice.

2. TO ATTACH HANDLE TO PUMP UNIT

2.1 Remove the handle component , insert it into the pump shell .

2.2 Remove the axle from plastic bag

2.3 Insert the axle at one end of the pump shell, then pump shell and handle components connection. Please note axle the position of the hole, Let the steel wire and nut on the chain through the axle hole (See the hydraulic system diagram and the handle component diagram).

2.4 Spring pin fixed the axle

2.5 Handle press the pump plunger, and remove the pin.

2.6 Raise the crank link and put the pin on rod and chain into the groove of crank link .

3. TO ADJUST RELEASE DEVICE

On the handle of the pallet truck, you will find the control lever which can be set in three positions (See Fig. 1): LOWER=to lower the forks; NEUTRAL=to move the load; ASCENT=to raise the forks. After assembling the handle, you can adjust the three positions.

3.1 First tighten the setting screw on the crank link until the LOWER position function works.

3.2 If the forks elevate while pumping in the NEUTRAL position, turn the setting screw clockwise until pumping the handle does not raise the forks and the NEUTRAL position functions correctly.

3.3 If the forks descend while pumping in the NEUTRAL position, turn the setting screw counter-clockwise until the forks do not lower.

3.4 If the forks do not descend when the control lever is in the LOWER position, turn the setting screw clockwise until raising the control lever lowers the forks. Then check the NEUTRAL position as per item 4.2 and 4.3.

3.5 If the forks do not lift while pumping in the ASCENT position, turn the setting screw counter-clockwise until the forks elevate while pumping in the ASCENT position. Then check the NEUTRAL and LOWER position as per item 4.2, 4.3 and 4.4.

4. MAINTENANCE

4.1 OIL

Please check the oil level every six months. Total oil amount is about 260 ml, add injection oil 50-100 ml, this must be with the forks in the lowered position.

Add or change the hydraulic oil according to the table below.

Temperature	Oil
-20°C~+40°C	L-HV46 Hydraulic oil

4.2 HOW TO EXPEL AIR FROM THE PUMP UNIT

Air may enter the unit when the seals are replaced. Lift the control lever to the LOWER position, then

move the handle up and down for several times.

4.3 DAILY CHECK AND MAINTENANCE

Daily check of the pallet truck can limit wear and tear of the unit. Pay special attention to the wheels ,the axles , the handle , the forks and lift and lower control.

4.4 LUBRICATION

Use motor oil or grease to lubricate all moveable parts.

5. GUIDE TO SAFE OPERATION

For safe operation of the truck, please read all warning signs and instructions here and on the truck before using this truck.

- 5.1 Do not operate the pallet truck unless you are familiar with it and have been trained or authorised to do so.
- 5.2 Do not operate the truck unless you have checked its condition. Give special attention to the wheels, the handle assembly, the forks, lift and the lower control.
- 5.3 Do not use the truck on sloping ground.
- 5.4 Never place any part of your body in the lifting mechanism or under the forks or load. Do not carry passengers.
- 5.5 The operator should wear gloves and safety shoes for protection.
- 5.6 Do not handle unstable or loosely stacked loads.
- 5.7 Do not overload the truck.
- 5.8 Do not subject to unbalanced load, either side to side or along the length of the frame (refer to Fig. 2/B).
- 5.9 The capacity of the truck assumes an evenly distributed load with the centre of the load being at the halfway point of the length of the forks (refer to Fig. 2)
- 5.10 Make sure that length of the forks matches the length of the pallet.
- 5.11 Lower the forks to lowest height when the truck is not being used.
- 5.12 At other specific conditions or places, the operator should operate the pallet truck carefully.

6. TROUBLE SHOOTING

NO	TROUBLE	CAUSE	ACTION
1	The forks do not lift to maximum height.	-Not enough hydraulic oil.	-Add more oil.
2	The forks do not lift up.	-Not enough hydraulic oil. -The oil has impurities. -Discharge valve is out of adjustment. -Air in the hydraulic oil.	-Pour in more filtered oil. -Change the oil. -Adjust the setting screw . -Expel the air.
3	The forks do not descend.	-The rod and the pump cover are deformed resulting from a seriously unbalanced load. -A part has been broken or been deformed resulting from unbalanced load. -The setting screw is not in the correct position.	-Replace the rod or pump cover . -Repair or replace component. -Adjust the setting screw
4	Leaks	-Seals worn out or damaged. -Some parts may be cracked or	-Replace seals with new ones. -Check and replace with new ones.

		worn out.	
5	The forks descend without being lowered.	-Impurities in the oil cause the discharge valve (B) to fail to close. -Air in the oil. -Seals worn or damaged. -Discharge valve (B) is out of adjustment.	-Replace with filtered oil. -Expel the air. -Replace with new ones. -Adjust the setting screw .

7. WEIGHING OPERATION

- 7.1 Put the control lever in the LOWER position and lower the truck to lowest position.
- 7.2 Press the ① key to turn the system on. After the start-up sequence the indicator will display the weight.
- 7.3 Weighing method for gross weight::
Press the ZERO key to set the gross weight to 0. Put the forks under the pallet and check that the load is properly balanced. Put the control lever in the ASCENT position, pump the handle to make the forks rise until the pallet has left the ground. When the indicator is stable, the gross weight of the goods (total weight of the pallet and the goods) is shown.
- 7.4 Weighing method for net weight:
To display the weight of the goods without the weight of the pallet (or other container):
- 7.4.1 Weigh single standard pallet, for example: weight of pallet: 40kg.
- 7.4.2 Press the ZERO key, the indicator will display "0kg".
- 7.4.3 Remove the pallet from the forks, the indicator will display "-40kg".
- 7.4.4 Weigh the goods on the pallet as shown in 7.3, when the indicator is stable, the net weight of the goods is shown.
- 7.5 Switch between kg and lb.
When the weight is shown in kg's, Press on the ZERO key will soon be kg to switch to the pound. Press on the ZERO key again and the unit shown will switch back to kg.
- 7.6 Turn off the Indicator
Press on the ON / OFF key until the indicator displays "OFF". Releasing the key will turn off the indicator.

8. BATTERY POWER DATA AND REPLACEMENT

- 8.1 How to change batteries:
- 8.1.1 Loosen the screws on the battery cover and remove the cover.
- 8.1.2 open the screw on battery and pull out battery ,out the socket.
- 8.1.3 put the new battery and insert the socket.
- 8.1.4 Screw the battery cover plate back into position.

Fig.1

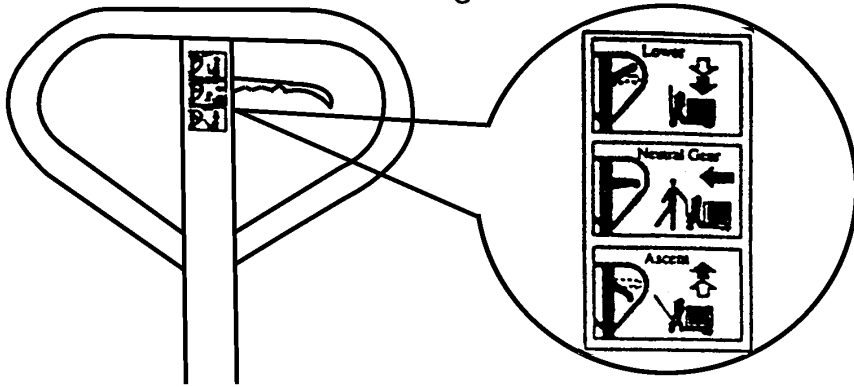
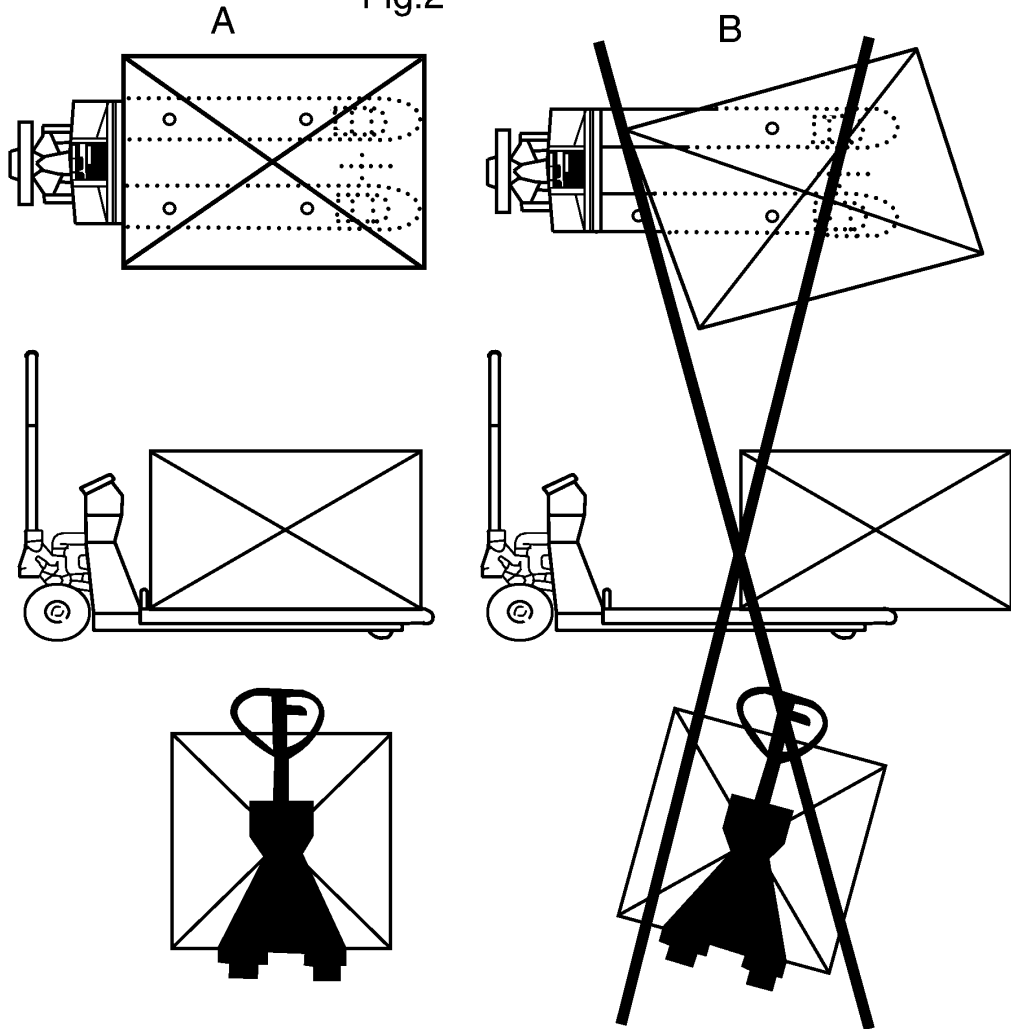
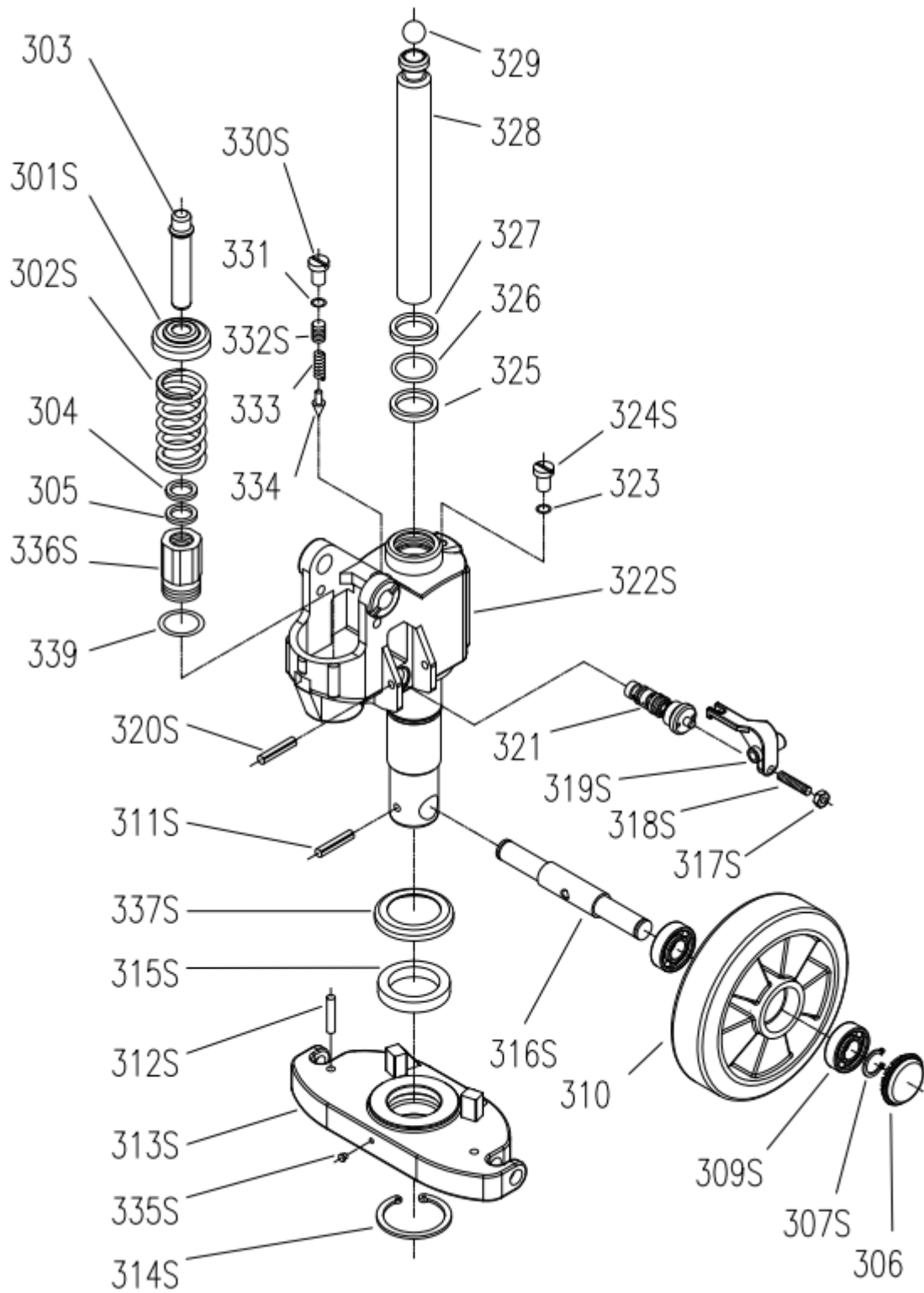

Fig.2



PARTS DRAWING OF PUMP ASSEMBLY



PARTS LIST OF PUMP ASSEMBLY

No.	Description	Q'ty	No.	Description	Q'ty
301S	Spring Cap	1			
302S	Spring	1			
303	Pump Piston	1			
304	Dust Ring	1			
305	Seal	1			
306	Dust Cover	2			
307S	Locking Ring	2			
309S	Bearing	4			
310	Loading Wheel	2			
311S	Elastic Pin	1			
312S	Elastic Pin	2			
313S	Thrust Plate	1			
314S	Retaining Ring	1			
315S	Bearing	1			
316S	Shaft of loading Wheel	1			
317S	Nut	1			
318S	Screw	1			
319S	Lever Plate	1			
320S	Elastic Pin	1			
321	Valve Cartridge	1			
322S	Pump Body	1			
323	Seal Washer	1			
324S	Screw Plug	1			
325	Seal	1			
326	O-Ring	1			
327	Dust Ring	1			
328	Piston Rod	1			
329	Steel Ball	1			
330S	Spring	1			
331	O-Ring	1			
332S	Bolt	1			
333	Spring	1			
334	Spindle of safety valve	1			
335S	Grease Cup	1			
336S	Cylinder	1			
337S	Cover of Bearing	1			
339	Seal Ring	1			

PARTS DRAWING OF HANDLE

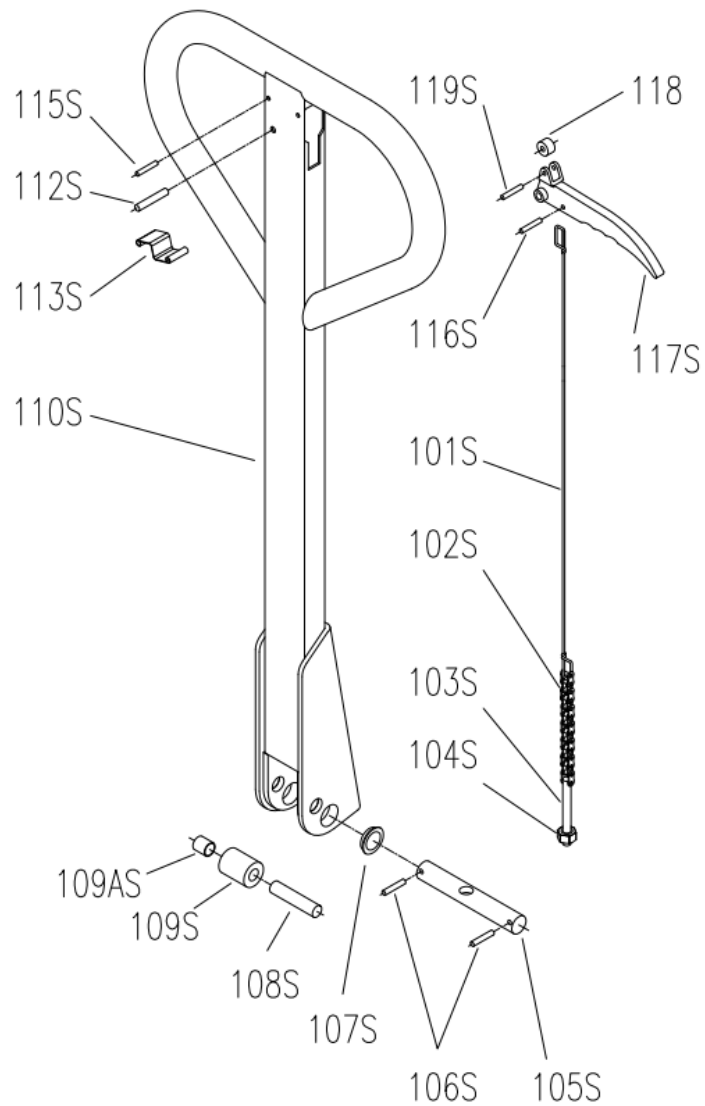

PARTS LIST OF HANDLE

No.	Description	Q'ty	No.	Description	Q'ty
101S	Release Rod	1	109AS	Bushing	1
102S	Chain	1	110S	Draw-bar	1
103S	Adjusting Bolt	1	112S	Elastic Pin	1
104S	Adjusting Nut	1	113S	Blade Spring	1
105S	Axle with Hole	1	115S	Elastic Pin	1
106S	Elastic Pin	2	116S	Elastic Pin	1
107S	Bushing	2	117S	Control Handle	1
108S	Roller Pin	1	118	Roller	1
109S	Pressure Roller	1	119S	Elastic Pin	1

PARTS DRAWING OF FRAME

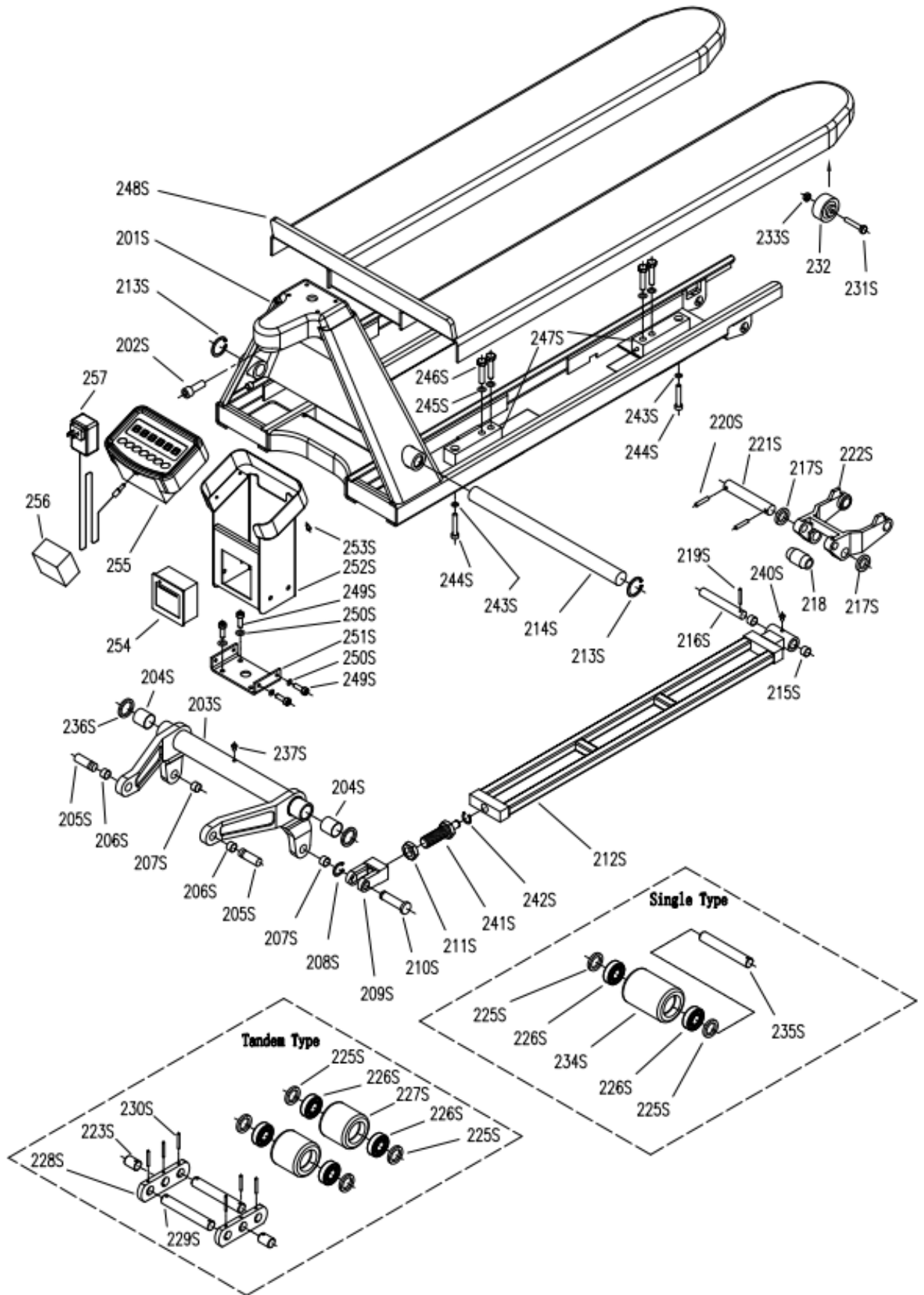

PARTS LIST OF FRAME

No.	Description	Q'ty	No.	Description	Q'ty
201S	Fork frame	1	241S	Screw shaft	2
202S	Screw	1	242S	The wire ring	2
203S	Rock- Arm	1	243S	Washer	4
204S	Bushing	2	244S	Screw	4
205S	Shaft	2	245S	Washer	8
206S	Bushing	2	246S	Screw	4
207S	Bushing	2	247S	The weighing sensor	4
208S	Retaining ring	2	248S	Weighing plate	1
209S	Joint	2	249S	Screw	8
210S	Pin	2	250S	Washer	8
211S	Nut	2	251S	The connecting plate	1
212S	Pushing rod	2	252S	Instrument shell	1
213S	Retaining ring	2	253S	Screw	4
214S	Shaft	1	254	Printer	1
215S	Bushing	2	255	Weighing display	1
216S	Shaft	2	256	Rechargeable battery	1
217S	Intermediate roller	4	257	Charger	1
218	Extending roller	2			
219S	Elastic pin	2			
220S	Elastic pin	4			
221S	Shaft	2			
222S	Frame of roller	2			
223S*	Shaft	4			
225S	Washer	8 or 4			
226S	Bearing	8 or 4			
227S*	Loading roller	4			
228S*	Link plate	4			
229S*	Shaft for roller	4			
230S	Elastic pin	12 or 2			
231S	Bolt	2			
232	Enter roller	2			
233S	Locking nut	2			
234S#	Loading roller	2			
235S#	Shaft for roller	2			
236S	Washer	2			
237S	Grease Cup	1			
240S	Grease Cup	2			

NOTE: *--For double wheel ; #--For single wheel

9. WIRING DIAGRAM OF SCALE, SENSOR

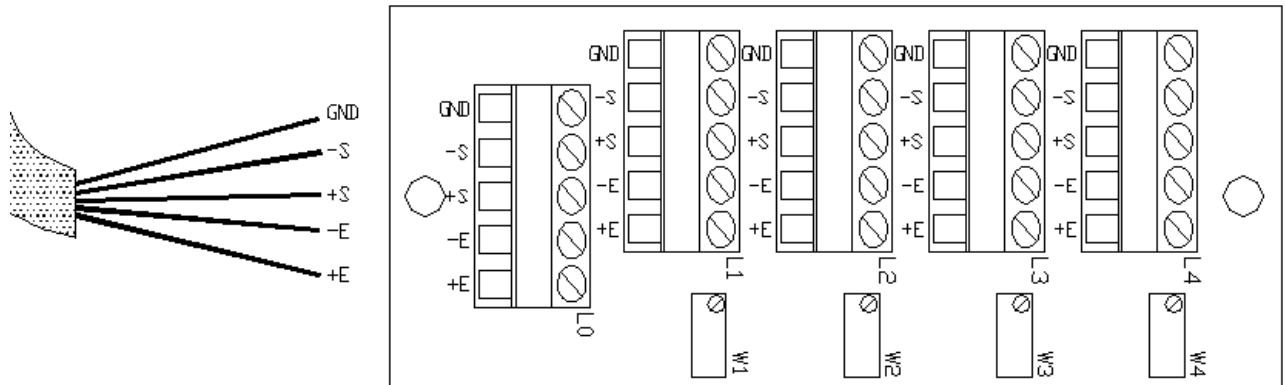

L0 —Connect meter connector	
GND	silver
-S	white
+S	green
-E	black
+E	red

L1~L4 Connect sensor connector	
GND	silver
-S	white
+S	green
-E	black
+E	red

10. CHANGING THE PAPER

10.1 Pull the lever to open the cover of the printer. Place the paper roll. Make sure the flap is at the top of the printer, facing towards you. Hold on to the paper when closing the printer. Push the cover closed firmly.

11. TROUBLE SHOOTING OF WEIGHING UNIT

NO	TROUBLE	CAUSE	SHOOTING
1	The instrument shows:OVER	-The load is too big for the scale	-Remove the load immediately.
2	Text is not printed clearly on the ticket	-Battery voltage is too low	-Charge the batteries.
3	The scale is not accurate	-The fork shoe is touching the bottom part of the scale -Cable in junction box is loose. -1 of the load cells is broken	-Remove anything that restricts the movement of the scale. -Check the connection in junction box after confirming safe. -Stand on the 4 corners of the scale. The load cell in the corner with a different weight should be replaced.
4	Indicator can't be turned on.	-Battery voltage is too low. -Battery life is complete. -Charger is damaged.	-Charge the batteries. -Replace rechargeable battery with new ones. -Check charger output voltage replace charger with new one.
5	Battery can't be charged.	-Battery is damaged. -Charger is damaged.	-Replace rechargeable battery with new ones. -Check charger output voltage replace charger with new one.