

SPARE PARTS LIST

Electric Pallet Truck PTE15N

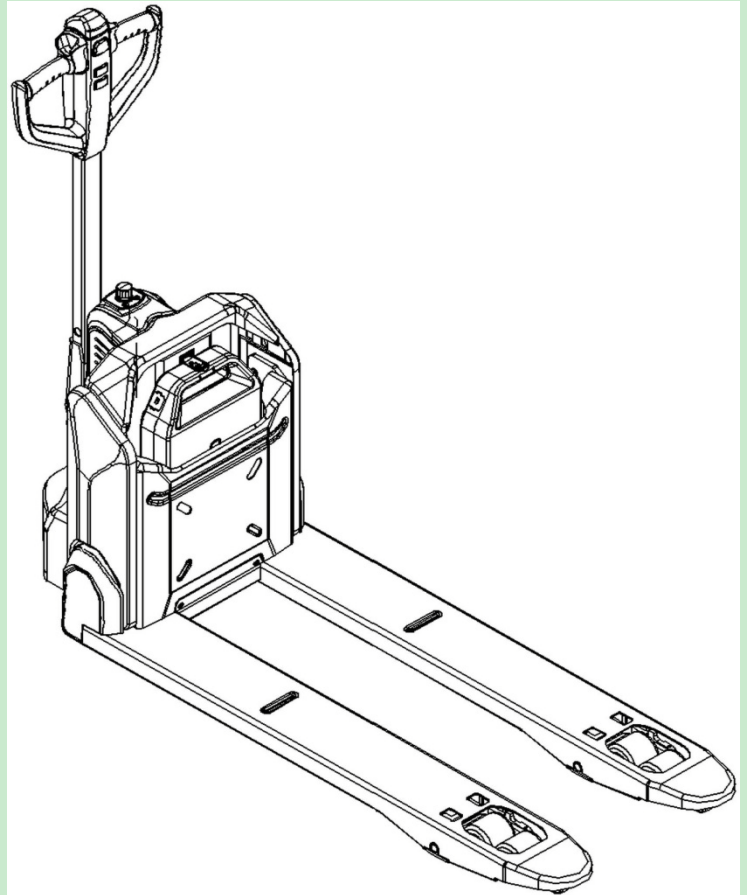

Version 04/2020

From truck identification number:

20191200000

PTE15N -BPT-012N

Catalogue

Fig. 1 Chassis (540x800/915/1000/1150/1220).....	3
Fig. 2 Chassis (685x800/915/1000/1150/1220).....	6
Fig. 3 Load roller components	9
Fig. 4 Driving unit.....	11
Fig. 5 Driving wheel components	13
Fig. 6 Cylinder.....	14
Fig. 7 Power unit.....	15
Fig. 8 Hydraulic components	16
Fig. 9 Steering wheel components (with side rollers).....	17
Fig. 10 Steering wheel components (without side rollers).....	18
Fig. 11 Tiller head.....	19
Fig. 12 Tiller arm components	21
Fig. 13 Truck components	22
Fig. 14 Power supply assembly.....	24
Fig. 15 Controller components	25
Fig. 16 Load Backrest Components	27
Fig. 17 Charger	28
Fig. 18 Wiring harness.....	30
Fig. 19 Sticker (EU).....	31
Fig. 20 Sticker (US).....	33
Easy worn parts list.....	34

Fig. 1 Chassis (540x800/915/1000/1150/1220)

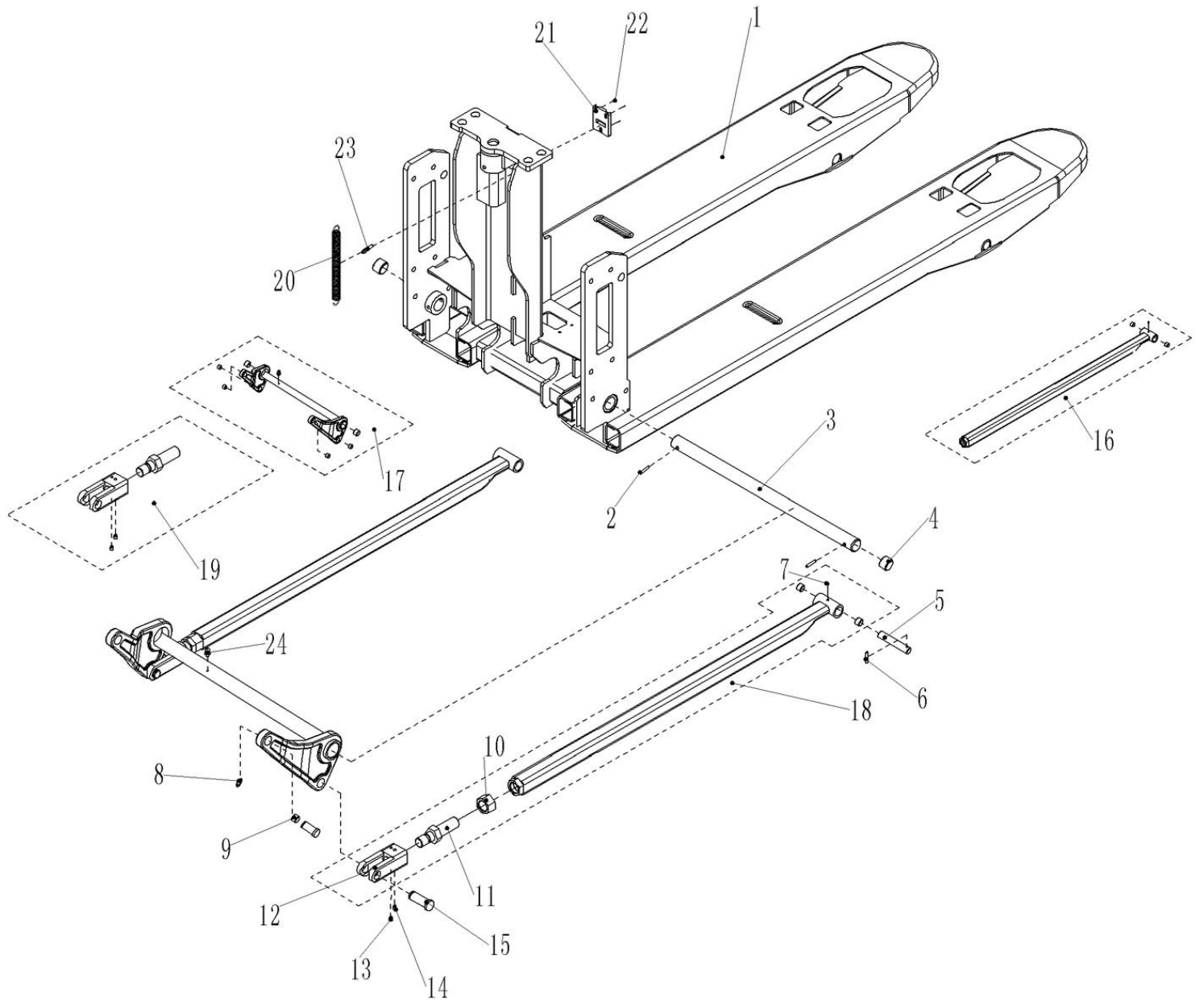

Fig. 1 Chassis (540x800/915/1000/1150/1220)

No.	Art No.	Description	Qty.	Note
1	508038510004	Chassis welding (540x800)	1	
	508038530001	Chassis welding (540x915)	1	
	508038510005	Chassis welding (540x1000)	1	
	508038510000	Chassis welding (540x1150)	1	
	508038510009	Chassis welding (540x1220)	1	
2	910600400041	Elastic cylindrical pin GB879.1-6x40	2	
3	508038520027	Axle Φ 24.6x462	1	
4	940500100097	Bushing Φ 24.6x Φ 29x25-SF-1(with oil hole)	2	
5	502338520030	Push rod axle Φ 16x82	2	
6	910600400024	Elastic cylindrical pin GB879.1-5x28	2	
7	911200100001	Grease nipple JB7940.4-6	2	
8	910401300007	Circlip GB894.1-16	4	
9	940500100083	Bushing Φ 16x Φ 18x15-SF-1(with oil hole)	8	
10	910300400008	Nut GB6173-M20x1.5-05	2	
11	508038520029	Adjusting bolt	2	
12	508038520028	Push rod fork	2	
13	910201000005	Screw GB79-M6x8-45H	2	
14	910600400015	Elastic cylindrical pin 4x30	2	
15	508038520041	Pin Φ 16x44	4	
16	508098510037	Push rod components (800)	2	800
	508098510005	Push rod components (915)	2	915
	508098510040	Push rod components (1000)	2	1000
	508098510000	Push rod components (1150)	2	1150
	508098510041	Push rod components (1220)	2	1220
17	508098510001	Rock arm components (540)	1	
18	508098510038	Push rod kits (800)	2	1150
	508098510006	Push rod kits (915)	2	915
	508098510043	Push rod kits (1000)	2	1000
	508098510002	Push rod kits (1150)	2	1150
	508098510044	Push rod kits (1220)	2	1220
19	508098510004	Push rod fork components	2	

20	380621520042	Spring Φ 10.4x Φ 1.6x160	1	
21	508038520109	Lock catch	1	
22	910200500034	Screw GB818-M4x8-4.8	3	
23	910100600001	Bolt GB798-M6x20-5.6	2	
24	911200100002	Oil Cup JB7940.1-M6x1	1	

Fig. 2 Chassis (685x800/915/1000/1150/1220)

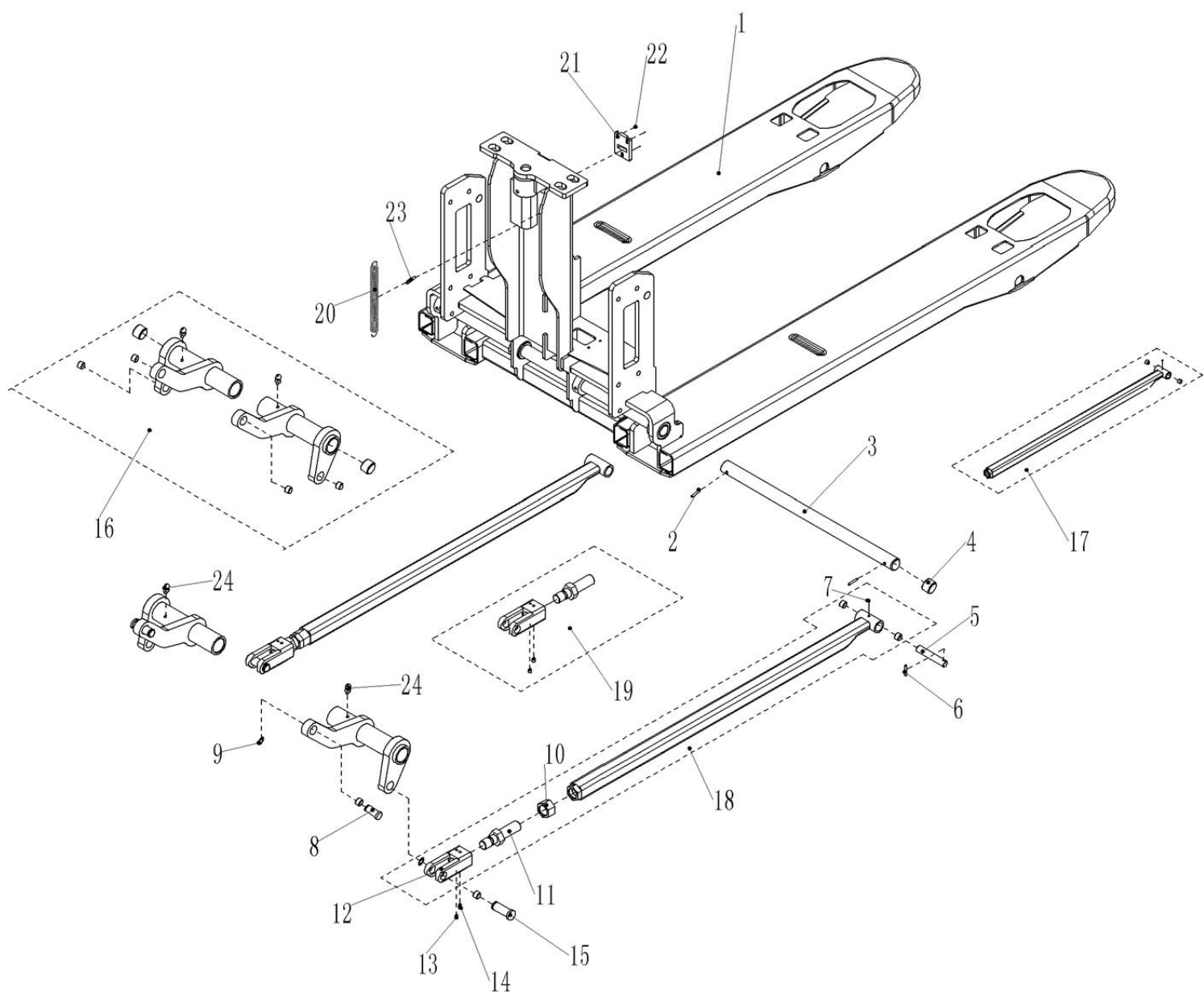

Fig. 2 Chassis (685x800/915/1000/1150/1220)

No.	Art No.	Description	Qty.	Note
1	508038510008	Chassis welding (685x800)	1	
	508038510002	Chassis welding (685x915)	1	
	508038510006	Chassis welding (685x1000)	1	
	508038510001	Chassis welding (685x1150)	1	
	508038510025	Chassis welding (685x1220)	1	
2	910600400041	Elastic cylindrical pin GB879.1-6x40	2	
3	508038520035	Axle Φ 24.6x609	1	
4	940500100097	Bushing Φ 24.6x Φ 29x25-SF-1(with oil hole)	4	
5	502338520030	Push rod axle Φ 16x82	2	
6	910600400024	Elastic cylindrical pin GB879.1-5x28	2	
7	911200100001	Grease nipple JB7940.4-6	2	
8	940500100083	Bushing Φ 16x Φ 18x15-SF-1(with oil hole)	8	
9	910401300007	Circlip GB894.1-16	4	
10	910300400008	Nut GB6173-M20x1.5-05	2	
11	508038520029	Adjusting bolt	2	
12	508038520028	Push rod fork	2	
13	910201000005	Screw GB79-M6x8-45H	2	
14	910600400015	Elastic cylindrical pin 4x30	2	
15	508038520041	Pin Φ 16x44	4	
16	508098510003	Rock arm components (685)	1	
17	508098510037	Push rod components(800)	2	800
	508098510005	Push rod components (915)	2	915
	508098510040	Push rod components (1000)	2	1000
	508098510000	Push rod components (1150)	2	1150
	508098510041	Push rod components (1220)	2	1220
18	508098510038	Push rod kits (800)	2	800
	508098510006	Push rod kits (915)	2	915
	508098510043	Push rod kits (1000)	2	1000
	508098510002	Push rod kits (1150)	2	1150
	508098510044	Push rod kits (1220)	2	1220
19	508098510004	Push rod fork components	2	

20	380621520042	Spring Φ 10.4x Φ 1.6x160	1	
21	508038520109	Lock catch	1	
22	910200500034	Screw GB818-M4x8-4.8	3	
23	910100600001	Bolt GB798-M6x20-5.6	2	
24	911200100002	Oil Cup JB7940.1-M6x1	2	

Fig. 3 Load roller components

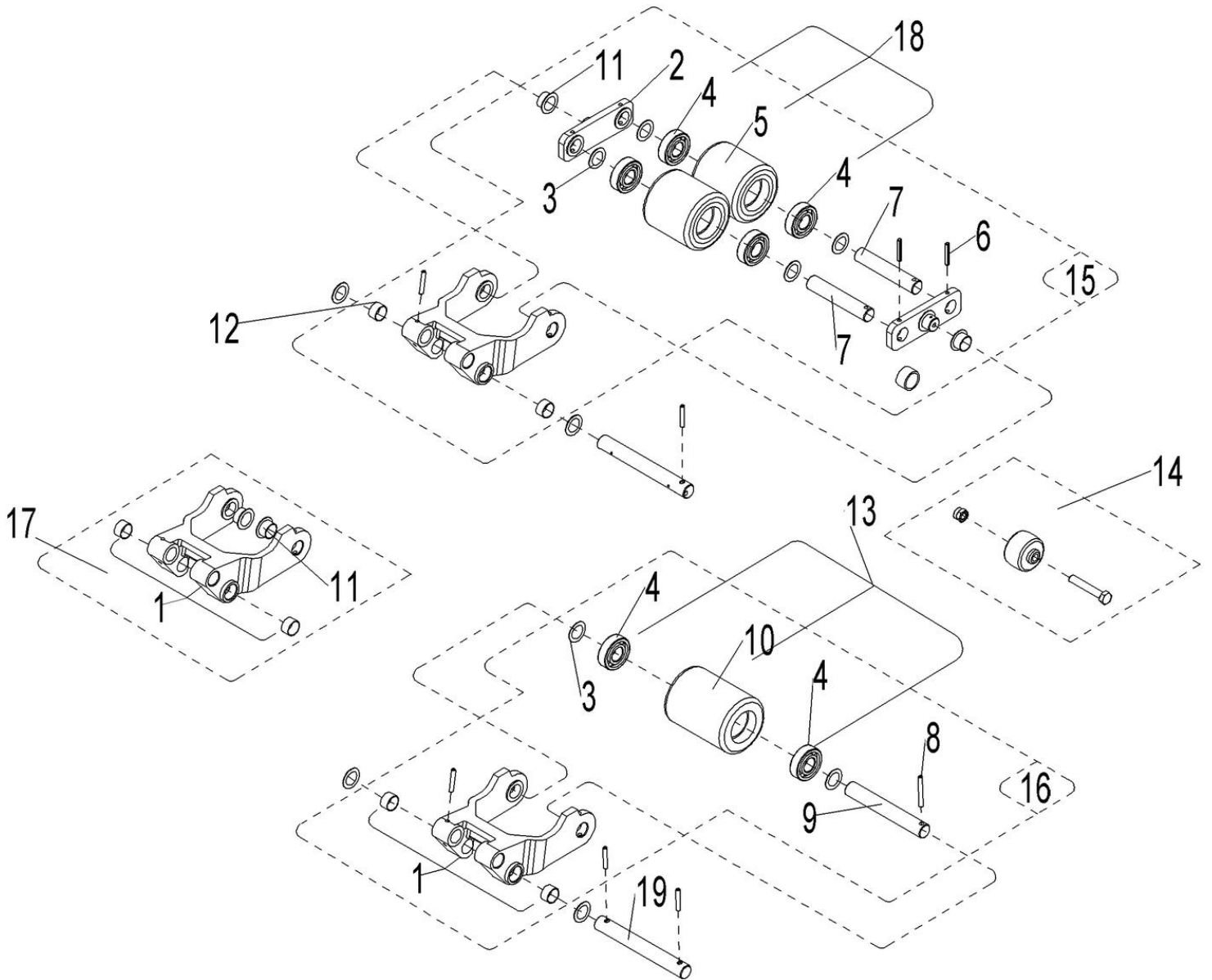

Fig. 3 Load Roller Components

No.	Art No.	Description	Qty.	Note
1	508098510048	Arm block assembly(Single wheel)	2	
2	502317020000	Linking plate	4	Tandem
3	940600500013	Washer $\Phi 25 \times \Phi 20.5 \times 1$	8/4 (Tandem/Single)	
4	910700200019	Bearing GB276-6204-2RS	8/4 (Tandem/Single)	
5	940300300005	Roller $\Phi 80 \times 70$ (Steel core PU)	4 (Tandem)	
6	910600400027	Elastic cylindrical pin GB879.1-5x35	8 (Tandem)	
7	502317020001	Wheel axle $\Phi 20 \times 94$	4 (Tandem)	
8	910600400027	Elastic cylindrical pin GB879.1-5x35	8 (Tandem)	
9	301017020001	Wheel axle $\Phi 20 \times 122$	2 (Single)	
10	940300300023	Roller $\Phi 80 \times 93$ (Steel core PU)	2 (Single)	
11	940500200038	Bushing (With shoulder) $\Phi 18 \times \Phi 20 \times 12$ -SF-1(with oil hole)	4 (Tandem)	
12	940500100088	Bushing $\Phi 20 \times \Phi 22 \times 12$ -SF-1(with oil hole)	4	
13	502398510014	Wheel set accessories(single)	2	
14	502398510003	Roller kit	2	
15	508098510049	Wheel accessories(double)	2	
16	508098510050	Wheel accessories(single)	2	
17	508098510051	Arm block assembly(Double wheel)	2	
18	502398510002	Wheel set accessories(double)	4	
19	508038520030	axle $\Phi 20 \times 158$	2	

Fig. 4 Driving unit

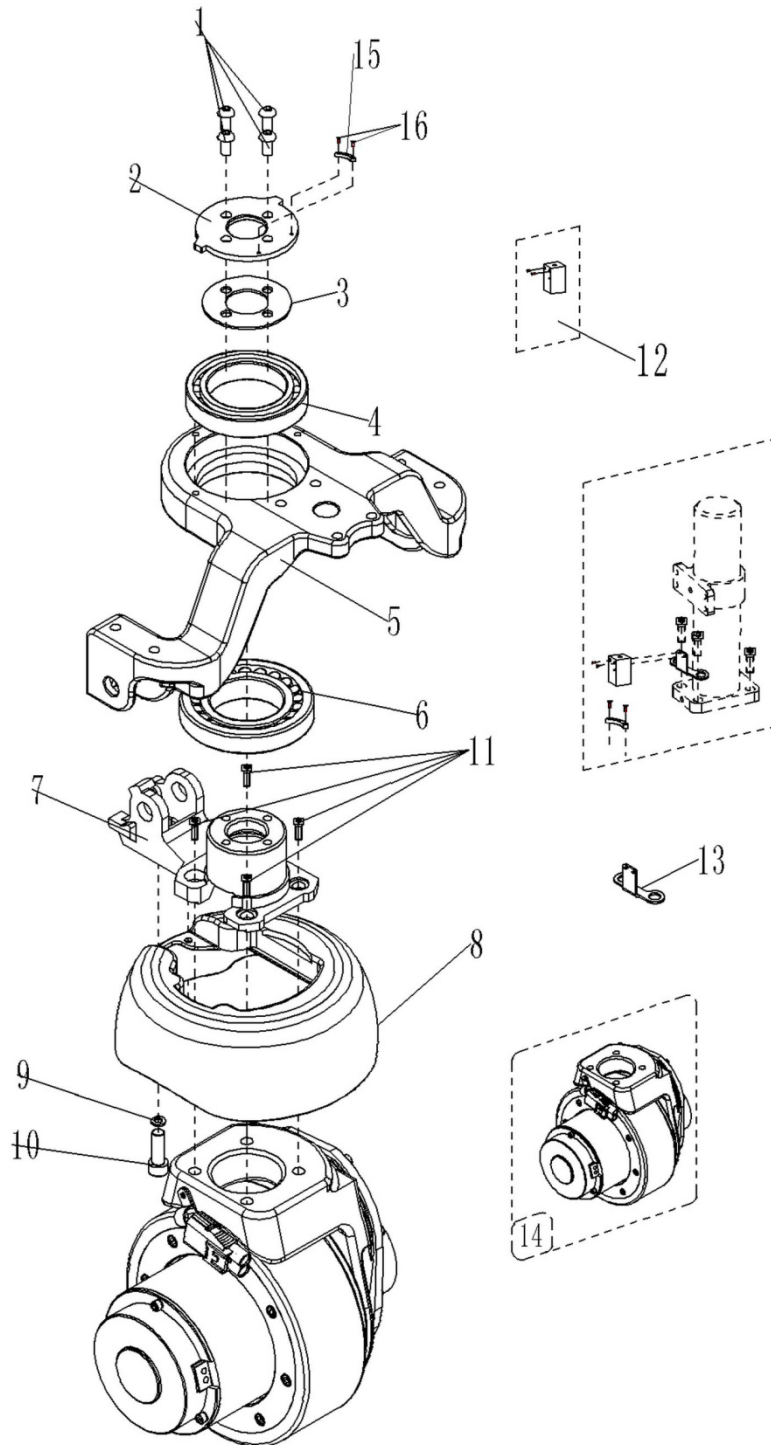

Fig. 4 Driving Unit

No.	Art No.	Description	Qty.	Note
1	910200300024	Screw GB70.2-M8x16-8.8	4	
2	508013520003	Bearing cap	1	
3	508013520004	Washer	1	
4	910700200058	Bearing GB276-6013-2RS	1	
5	508013520000	Driving wheel seat	1	
6	910700600044	Bearing GB297-32913	1	
7	508013520001	Linking flange	1	
8	508013520101	Round cover	1	
9	910400100005	Washer GB97.1-6-200HV	2	
10	910200200032	Screw GB70.1-M6x10-8.8	2	
11	910200200076	Screw GB70.1-M10x25-8.8	4	
12	508098510012	Proximity switch components	1	With speed reduction on curve
13	508033020003	Frame	1	With speed reduction on curve
14	508098510014	Driving components	1	
	508098510052	Driving components (PU, antiskid)		antiskid
15	508033020002	Induction block	1	
16	910200700001	Screw GB820-M4x10-4.8	2	

Fig. 5 Driving wheel components

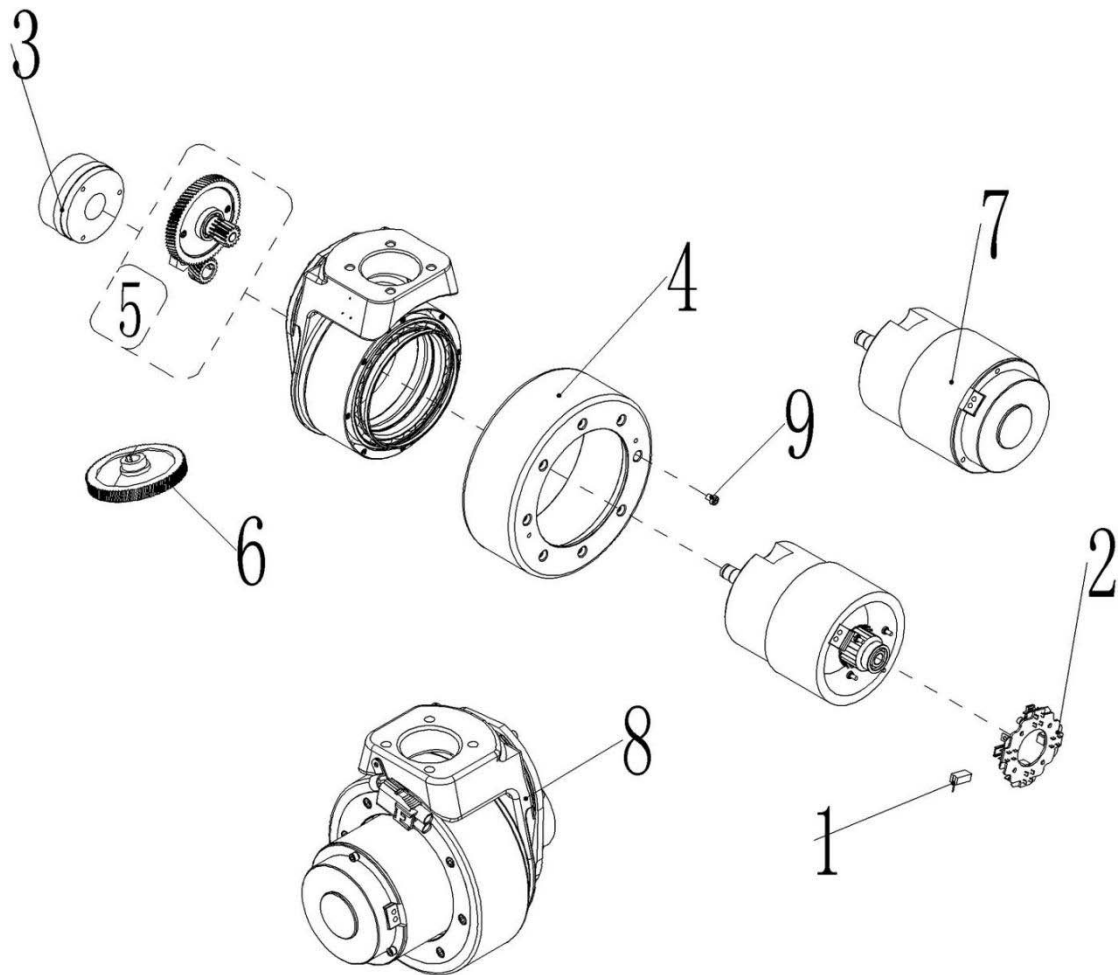

Fig. 5 Driving Wheel Components

No.	Art No.	Description	Qty.	Note
1	508098520000	Carbon brush	4	
2	508098520001	Carbon brush frame	1	
3	508098520002	Brake	1	
4	508098520003	Wheel	1	
	508098520026	Wheel(PU, antiskid)		antiskid
5	508098510015	Gearbox components	1	
6	508098520004	Big gear ring	1	
7	508098510016	Motor components	1	
8	508098510014	Driving components	1	
	508098510052	Driving components (PU, antiskid)		antiskid
9	910200200167	Screw pad assembly M6 x20-8.8	8	

Fig. 6 Cylinder

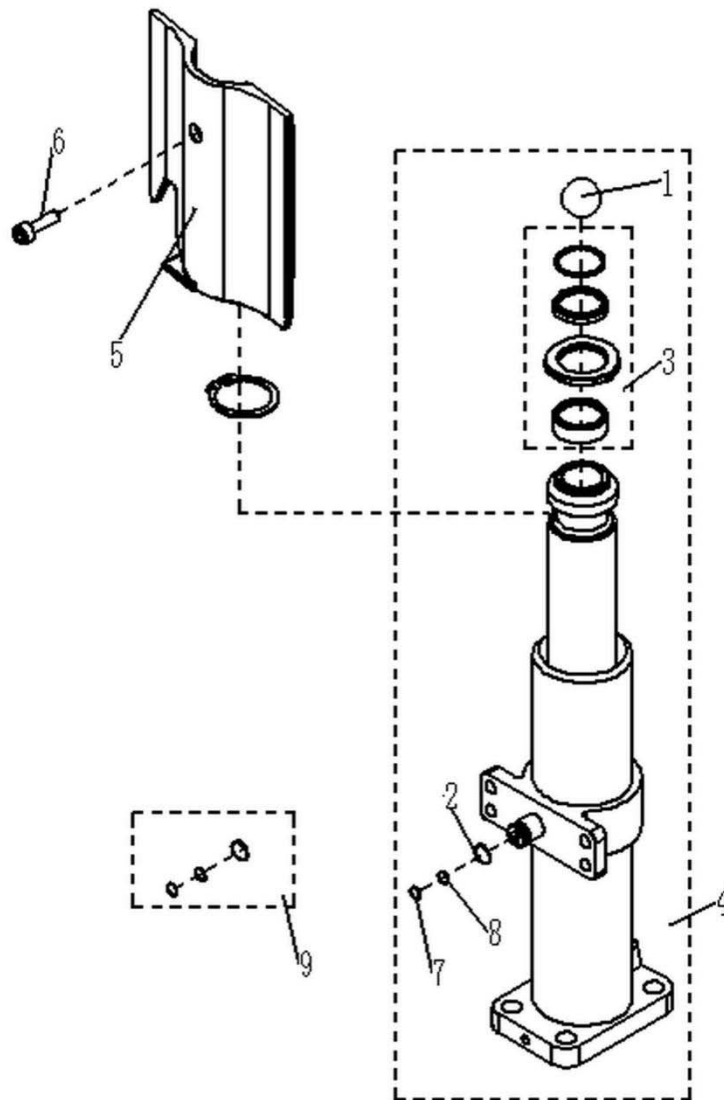

Fig. 6 Cylinder

No.	Art No.	Description	Qty.	Note
1	910701100019	Steel ball GB308-18	1	
2	910800100098	O ring	1	13.5x1.8
3	508098510018	Sealing components	1	
4	508024010003	Cylinder components	1	Frame number 201911000415
5	508024020103	Cover for cylinder	1	
6	910200200033	Screw GB70.1-M6x12-8.8	1	
7	910800800003	antiextrusion ring 12.7x9.8x1.25	1	
8	910800100001	O ring - within 9.5x1.8	1	
9	508598510004	Sealed assembly	1	Frame number 201911000415

Fig. 7 Power unit

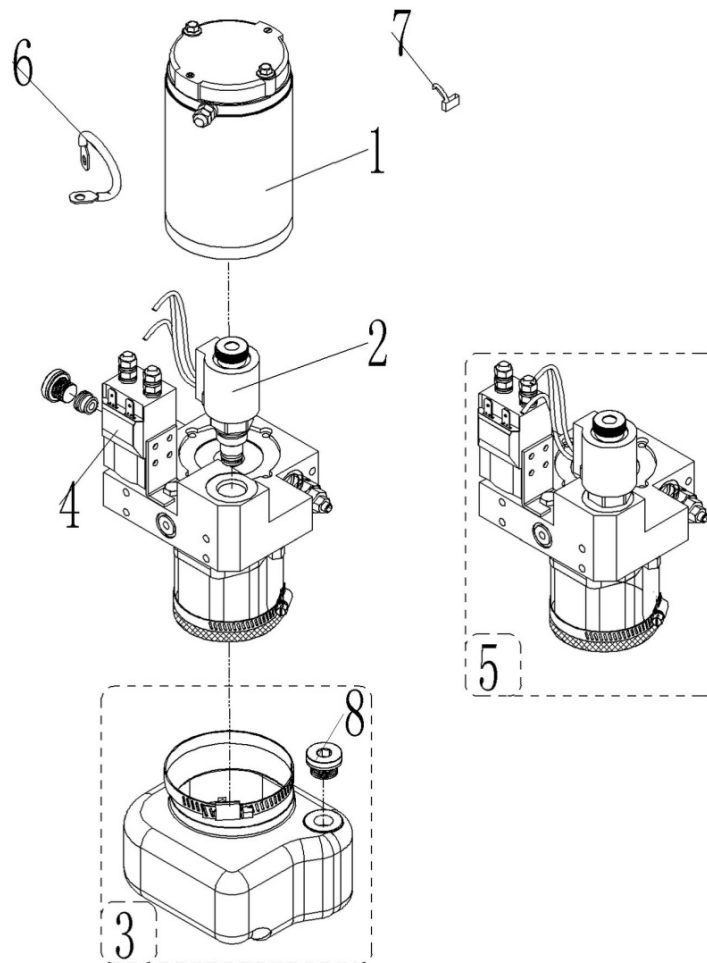

Fig. 7 Power Unit

No.	Art No.	Description	Qty.	Note
1	508098510020	DC Motor	1	MD24050
2	508098510034	Electromagnetic valve components	1	
3	508098510023	Oil tank components	1	
4	508098510021	Contactur	1	ZJWP80DE
5	508098510053	Gear pump assembly	1	Double seal
6	508098520007	Soft connection cable	1	RSWC-04
7	508098520008	Electric brush	1	
8	508598510009	Air Filter	1	Z3/8

Fig. 8 Hydraulic components

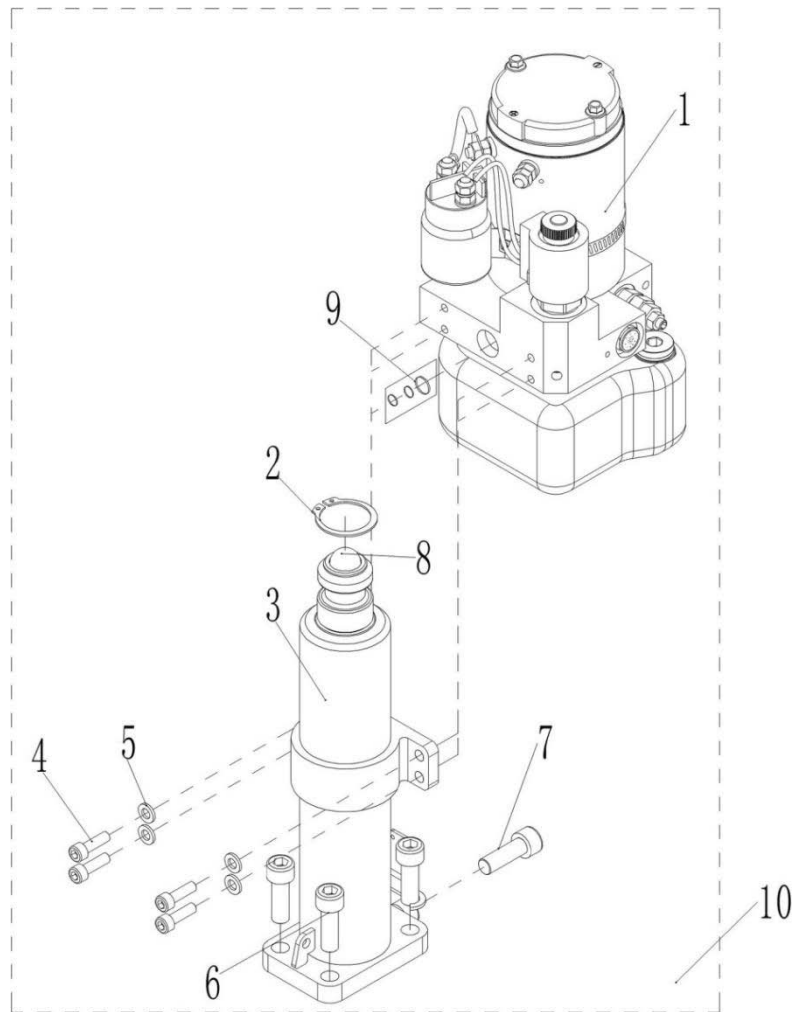

Fig. 8 Hydraulic Components

No.	Art No.	Description	Qty.	Note
1	950900100060	Hydraulic power unit 24V0.5KW0.38cc	1	Frame number 201911000415
2	910401300017	Circlip GB894.1-32	1	
3	508024010003	Cylinder assembly	1	Frame number 201911000415
4	910200200036	Screw GB70.1-M6x20-8.8	4	
5	910400100005	Flat washer GB97.1-6-200HV	4	
6	910200200077	Screw GB70.1-M10x30-8.8	4	
7	910200200160	Screw GB70.1-M6x6-12.9-c1B	1	
8	910701100019	Steel ball GB308-18	1	
9	508598510004	Sealed assembly	1	Frame number 201911000415
10	508098510054	Hydraulic components	1	Frame number 201911000415

Fig. 9 Steering wheel components (with side rollers)

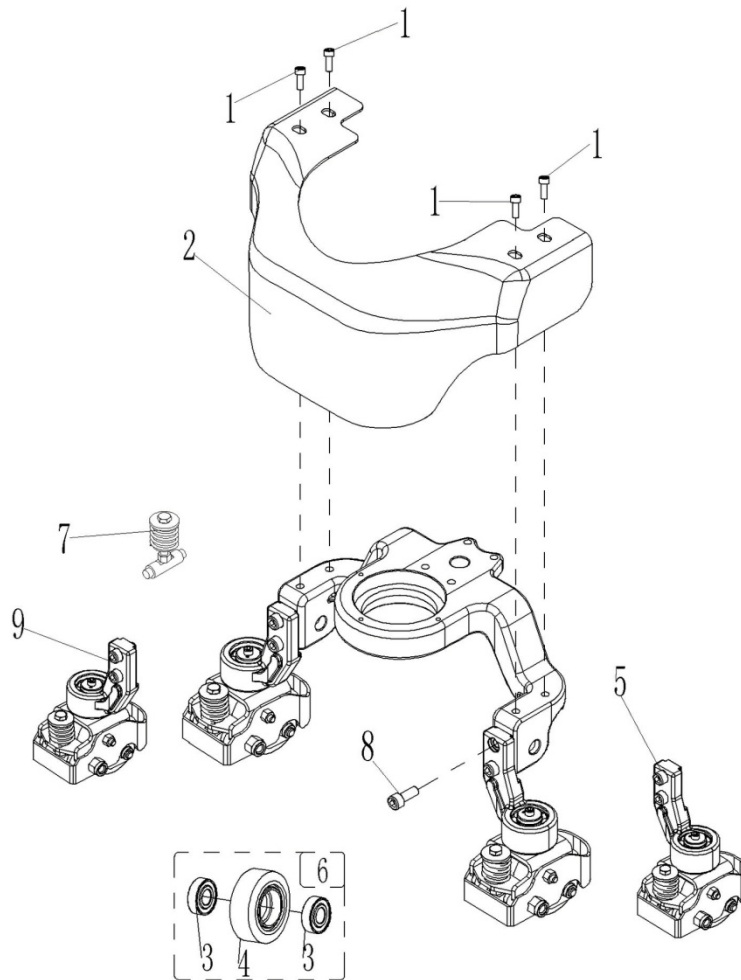

Fig. 9 Steering Wheel Components (with side rollers)

No.	Art No.	Description	Qty.	Note
1	941100100005	Screw M10x15-8.8	4	
2	508016520000	Apron (side roller)	1	Ground clearance: 35mm
	508016520008			Ground clearance: 45mm
3	910700200018	Bearing GB276-6203-2RS	2	
4	940300300017	Roller $\Phi 80 \times 30$ (Steel core PU)	1	
5	508016510005	Side roller components $\Phi 80 \times 30$ (PU/right)	1	
6	502398510015	Roller components	1	
7	508098510047	Spring components	1	
8	910200200076	Screw GB70.1-M10x25-8.8	4	
9	508016510002	Side roller components $\Phi 80 \times 30$ (PU/left)	1	

Fig. 10 Steering wheel components (without side rollers)

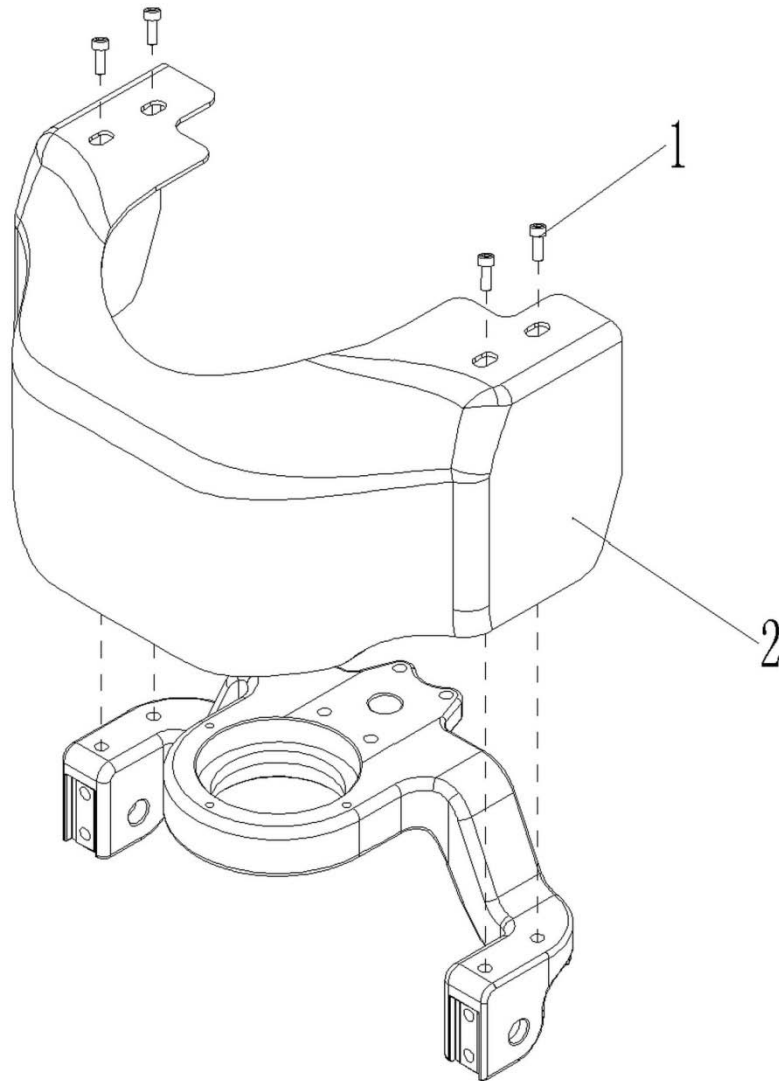

Fig. 10 Steering Wheel Components (without side rollers)

No.	Art No.	Description	Qty.	Note
1	941100100005	Screw M10x15-8.8	4	
2	508016520001	Apron (without side roller)	1	Ground clearance: 35mm
	508016520009			Ground clearance: 45mm

Fig. 11 Tiller head

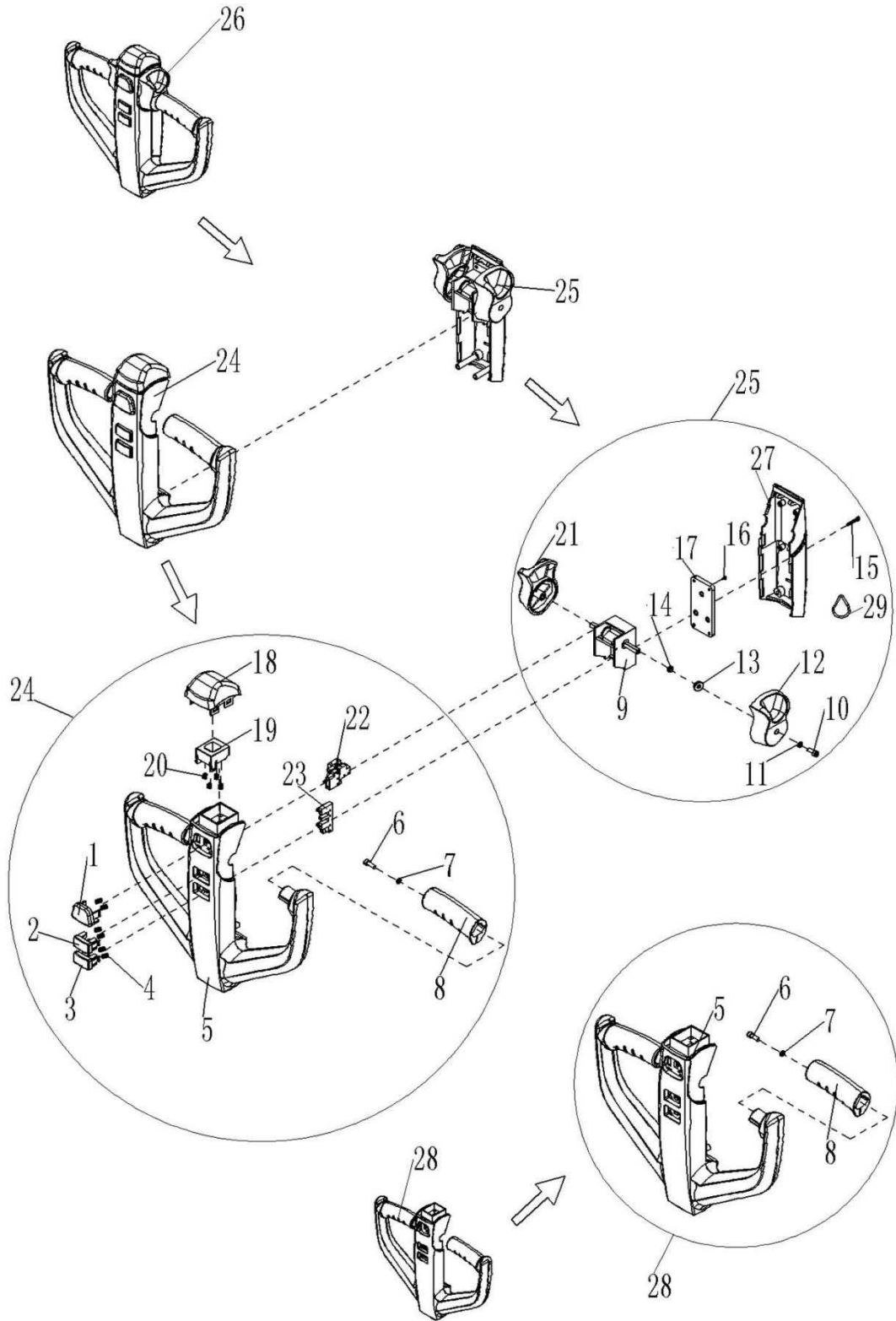

Fig. 11 Tiller Head

No.	Art No.	Description	Qty.	Note
1	508098520029	Horn	1	

2	508098520030	Lifting button	1	
3	508098520031	Lowering button	1	
4	502311020022	Spring 0.6	6	Height 16
5	508098520012	Tiller upper cover	1	
6	910200200058	Bolt	2	M8*25
7	910400500006	Washer	2	Φ8
8	508098520013	Grip	2	
9	508098510028	Accelerator assembly	1	components
	508098510055			With credit card function
10	910200200003	Bolt	2	M3*12
11	910400500002	Washer	2	Φ3
12	508098520014	Left driving knob	1	
13	508098520015	Axle external bushing	2	
14	508098520016	Axle internal bushing	2	
15	910200200159	Screw GB70.1-M5x50-8.8	2	M5*50
16	910202000001	Screw	3	M4*6
17	508098520017	Accelerator fixing plate	1	
18	508098520018	Belly button base	1	
19	508098520019	Belly internal base	1	
20	502311020018	Spring 0.8	4	Height 11
21	508098520020	Right driving knob	1	
22	508098510029	Horn micro switch components	1	
23	508098510030	Lifting and lowering micro switch components	1	
24	508098510031	Tiller upper cover components	1	
25	508098510032	Tiller bottom cover components	1	
	508098510056			With credit card function
26	922100100013	Tiller N200(12C-1)	1	
	922100100019	Tiller N200(12C-2)		With credit card function
27	508098510039	Display panel assembly	1	
28	508098510046	Handle cover fitting	1	
29	508098520027	Handle ID Card	1	With credit card function

Fig. 12 Tiller arm components

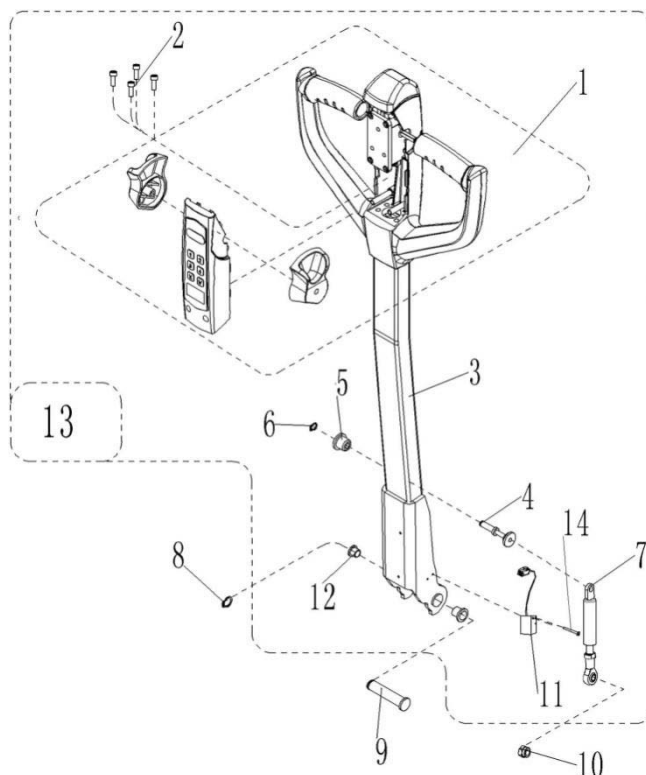

Fig. 12 Tiller Arm Components

No.	Art No.	Description	Qty.	Note
1	922100100013	Tiller N200(12C-1)	1	With credit card function
	922100100019	Tiller N200(12C-2)		
2	910200200040	Screw GB70.1-M6x35-8.8	4	
3	508011010000	Tiller arm welding	1	
4	508011010002	Fixing axle welding	1	
5	508011020005	Fixing base	1	
6	910401300001	Circlip GB894.1-8	1	
7	508011010001	Air spring (D245)	1	
8	910401300006	Circlip GB894.1-15	1	
9	508011020004	Pin $\Phi 15 \times 70$	1	
10	910200200057	Screw GB70.1-M8x20-8.8	1	
11	505633510002	Proximity switch NBN5-F7-E2(800mm)	1	
12	940500200001	Bushing (With shoulder) $\Phi 15 \times \Phi 17 \times 9$ -SF-1	2	
13	508098510035	Tiller components	1	
14	910200200006	Screw GB70.1-M3x22-8.8	2	

Fig. 13 Truck components

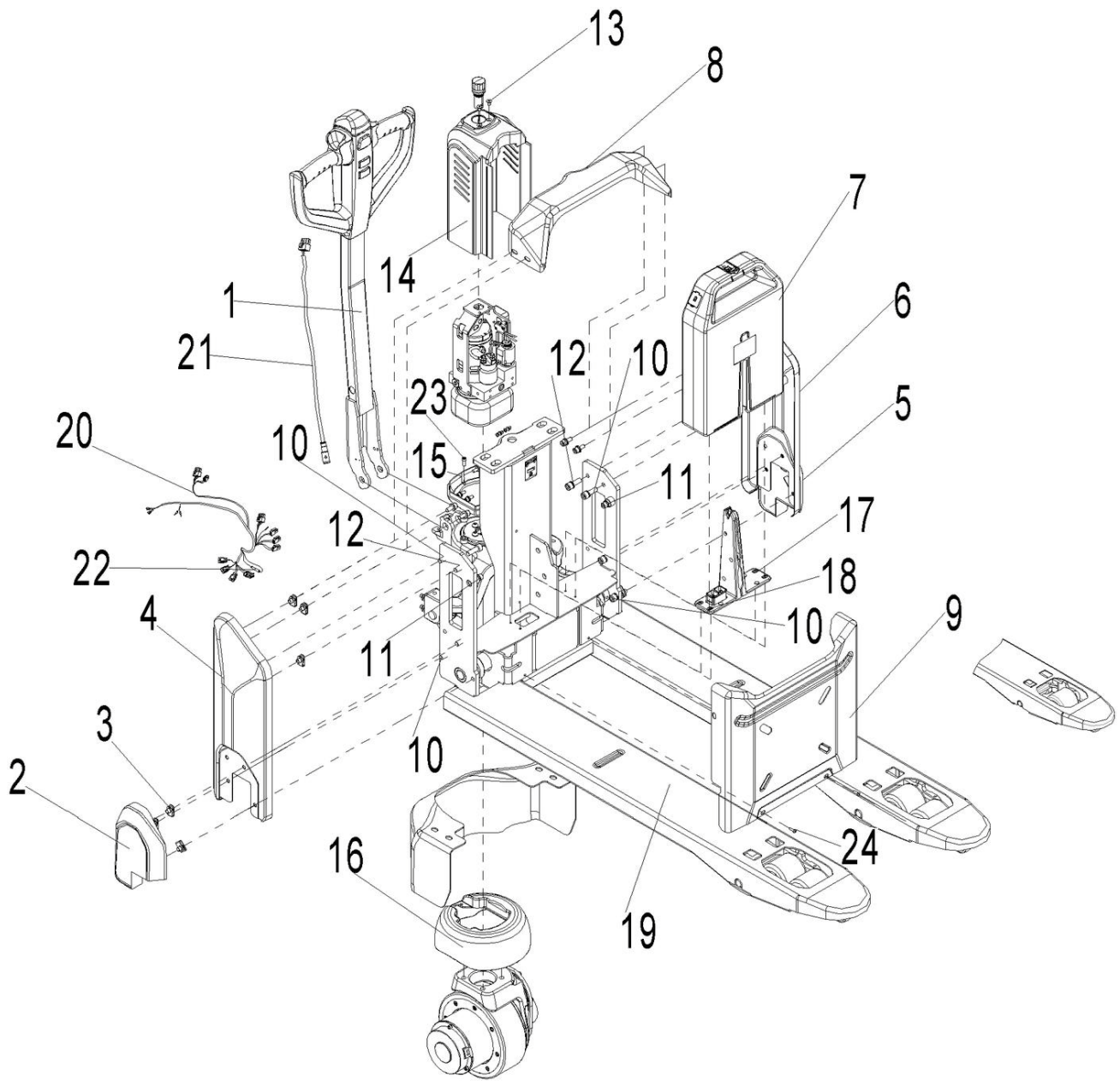

Fig. 13 Truck Components

No .	Art No.	Description	Qty.	Note
1	508098510035	Tiller assembly	1	
2	508038510103	Small side cover (right)(540)	1	
	508038510105	Small side cover (right)(685)	1	
3	940400400002	Nut M8-t(2-4)	14	
4	508038510101	Side panel (right)	1	

5	508038510102	Small side cover (left)(540)	1	
	508038510104	Small side cover (left)(685)	1	
6	508038510100	Side panel (left)	1	
7	508037010003	Lithium battery 24V20Ah	1	20Ah
	508037010004	Lithium battery 24V30Ah	1	30Ah
	508037010005	Lithium battery 24V36Ah	1	36Ah
8	508038520100	Top cover	1	
9	508038520101	Front cover	1	
10	910200200058	Screw GB70.1-M8x25-8.8	10	
11	910200200055	Screw GB70.1-M8x16-8.8	6	
12	910400100006	Flat washer GB97.1-8-200HV	6	
13	910200400015	Screw GB70.3-M6x10-8.8	2	
14	508024020101	Pump protective cover	1	
15	508024020102	Base cover	1	
16	508013520101	Round cover	1	
17	920600100045	Lithium battery guide base	1	
18	910200500037	Screw GB818-M5x10-4.8	4	M5x10
19	508038510004	Chassis welding (540x800)	1	
	508038530001	Chassis welding (540x915)		
	508038510005	Chassis welding (540x1000)		
	508038510000	Chassis welding (540x1150)		
	508038510009	Chassis welding (540x1220)		
	508038510008	Chassis welding (685x800)		
	508038510002	Chassis welding (685x915)		
	508038510006	Chassis welding (685x1000)		
	508038510001	Chassis welding (685x1150)		
	508038510025	Chassis welding (685x1220)		
20	508033010000	Main control wiring harness	1	
	508033010009	Main control wiring harness	1	With speed reduction on curve
21	508033010001	Tiller control wiring harness	1	
22	920100200002	Fuse 10A	1	
23	910200200033	Screw GB70.1-M6x12-8.8	3	
24	910200500051	Screw GB818-M6x12-4.8	2	

Fig. 14 Power supply assembly

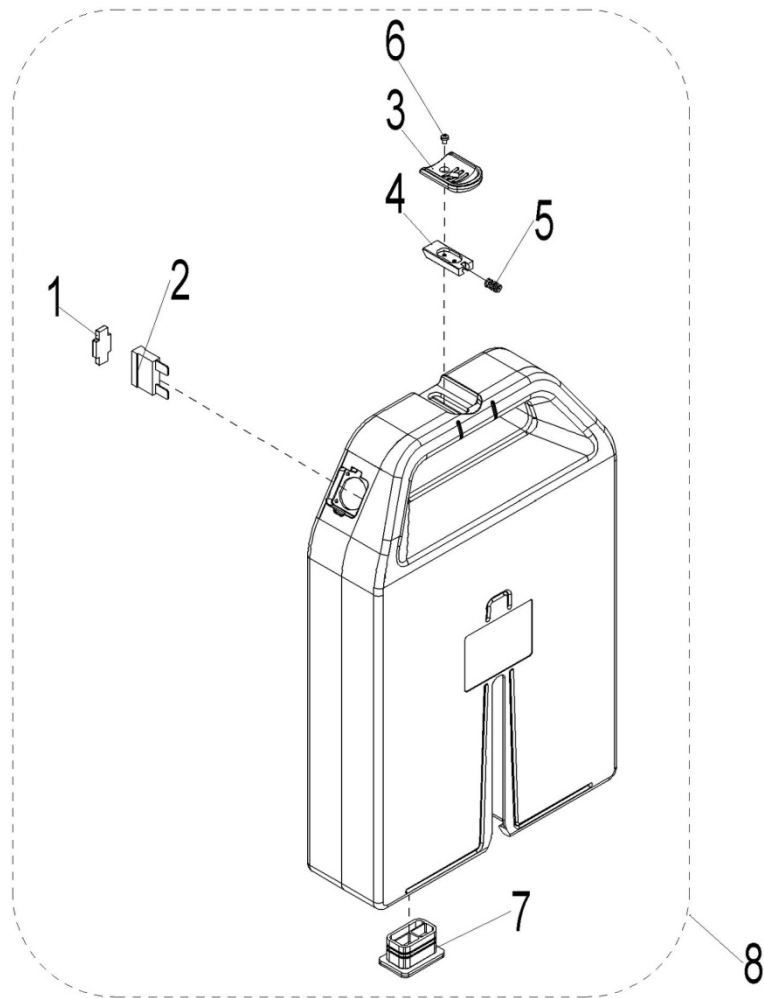

Fig. 14 Power Supply Assembly

No.	Art No.	Description	Qty.	Note
1	508098520021	Fuse protective cap	1	
2	920100200006	70A fuse	1	ATM70A DC32V
3	508098520022	Locker	1	
4	508098520023	Aluminium part	1	
5	508098520024	Spring	1	
6	910200500011	Screw	2	Screw GB818-M3x10-4.8
7	508098510069	Rubber Battery plug	1	
8	508037010003	Lithium battery 24V20Ah	1	20Ah
	508037010004	Lithium battery 24V30Ah	1	30Ah
	508037010005	Lithium battery 24V36Ah	1	36Ah

Fig. 15 Controller components

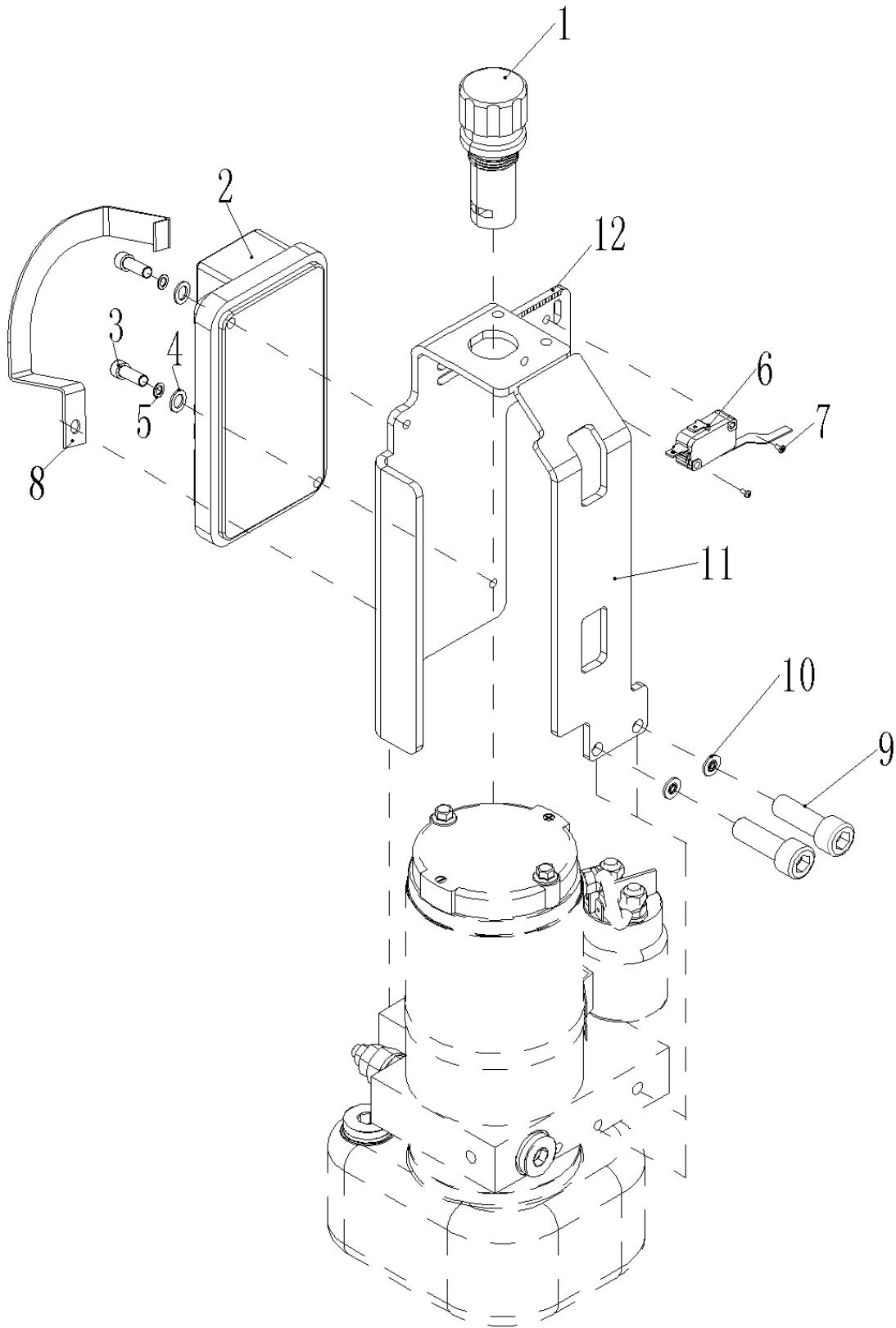

Fig. 15 Controller Components

No.	Art No.	Description	Qty.	Note
1	920200100015	Emergency button CE3T-10R-02	1	
2	921400100081	Controller 1212C-2503	1	
3	910200200025	Screw GB70.1-M5x25-8.8	2	Screw GB70.1-M5x25-8.8-c1B
4	910400100004	Flat washer GB97.1-5-200HV	2	Flat Washer GB97.1-5-200HV-A-c1B
5	910400500004	Washer GB93-5	2	Washer GB93-5-c1B
6	920200300012	Micro switch V-J163-1C25	1	
7	910200200003	Screw GB70.1-M3x12-8.8	2	Screw GB70.1-M3x12-8.8-c1B
8	508033020000	Cable clamp	1	
9	910200200036	Screw GB70.1-M6x20-8.8	3	Screw GB70.1-M6x20-8.8-c1B
10	910400100005	Flat Washer GB97.1-6-200HV	3	Flat Washer GB97.1-6-200HV-A-c1B
11	508024010002	Controller mounting rack	1	
12	921600300004	Free Insulation Sheath	1	KG-045

Fig. 16 Load Backrest Components

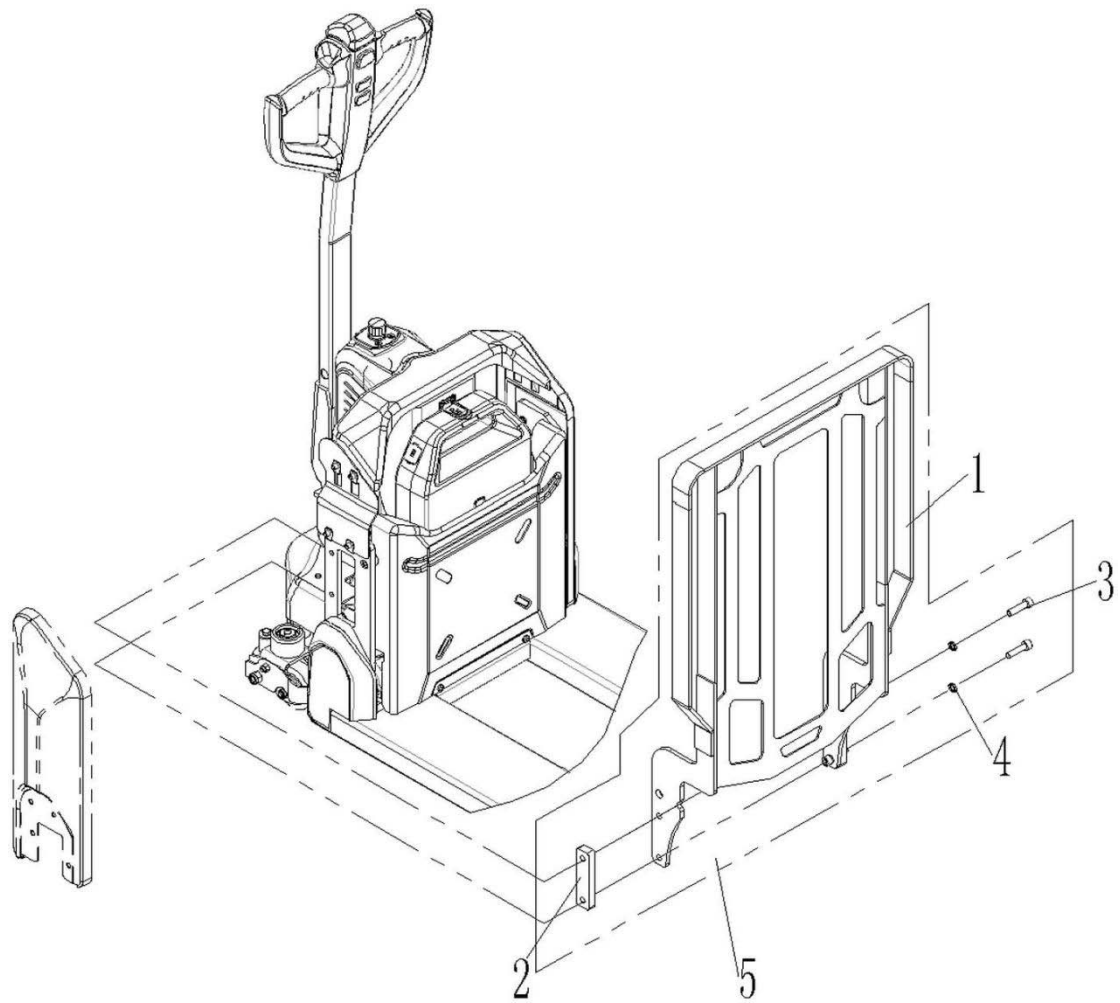

Fig. 16 Load Backrest Components

No.	Art No.	Description	Qty.	Note
1	508040510003	Load backrest welding (new1070)	1	
	508040510004	Load backrest welding (new 1220)	1	
	508040510005	Load backrest welding (new 1525)	1	
2	508040520000	Plate	2	
3	910200200079	Screw GB70.1-M10x40-8.8	4	
4	910400500007	Spring washer GB93-10	4	
5	508040501003	Load backrest assembly (new 1070)	1	
	508040501004	Load backrest assembly (new 1220)	1	
	508040501005	Load backrest assembly (new 1525)	1	

Fig. 17 Charger

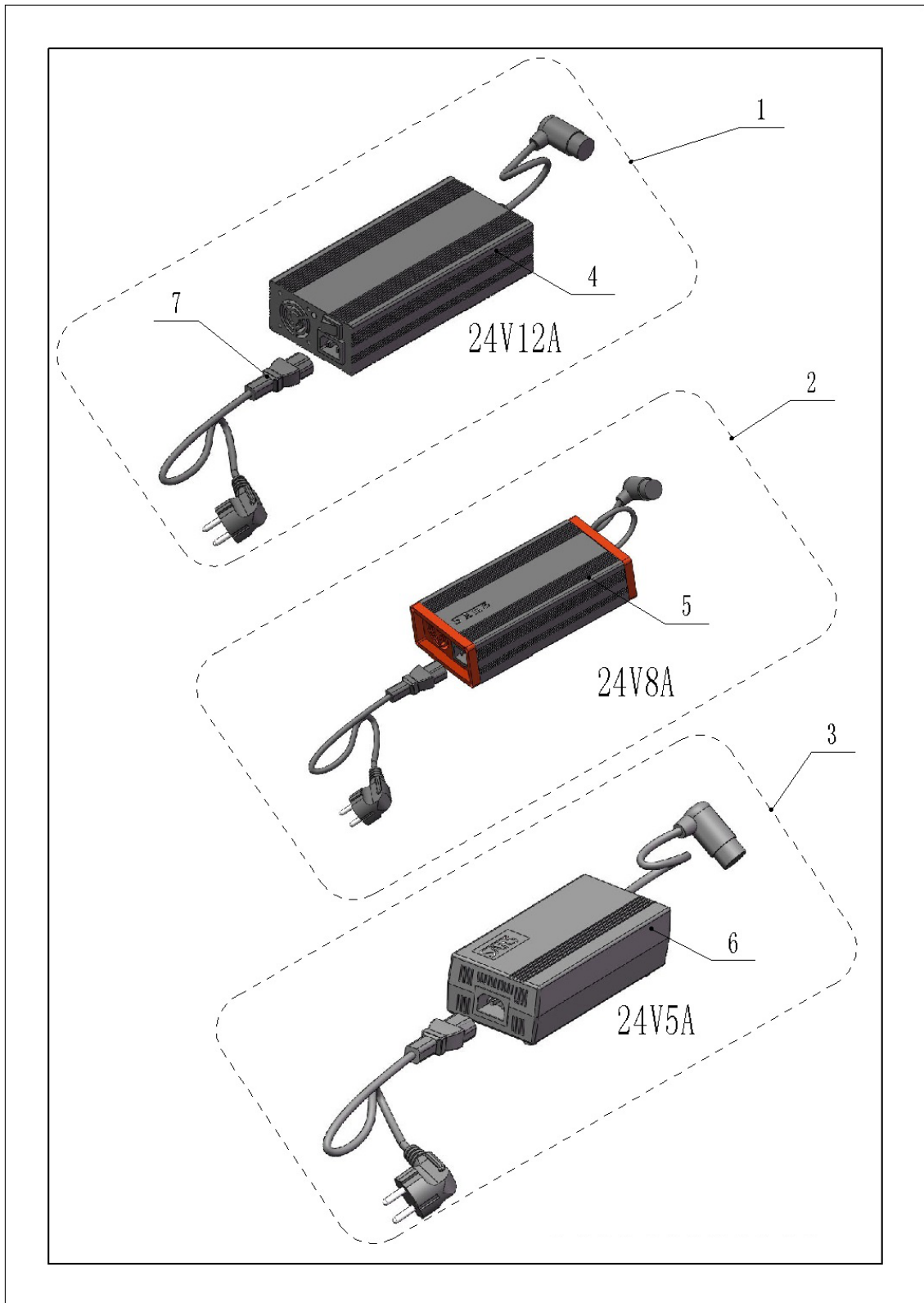

Fig. 17 Charger

No.	Art No.	Description	Qty.	Note
1	508036510013	Lithium charger 24V12A(Asia)	1	QQE
1	508036510014	Lithium charger 24V12A(ENG)	1	QQE
1	508036510015	Lithium charger 24V12A(US)	1	QQE
1	508036510016	Lithium charger 24V12A(EU)	1	QQE
1	508036510017	Lithium charger 24V12A(AUS)	1	QQE
1	508036510018	Lithium charger 24V12A(ITY)	1	QQE
1	508036510019	Lithium charger 24V12A(Sweden)	1	QQE
1	508036510020	Lithium charger 24V12A(Israel)	1	QQE
1	508036510021	Lithium charger 24V12A(Brazil)	1	QQE
1	508036510022	Lithium charger 24V12A(Argentina)	1	QQE
1	508036510038	Lithium charger 24V12A(South Africa)	1	QQE
1	508036510037	Lithium charger 24V12A(India)	1	QQE
2	921000200353	Lithium charger SS24V8A(Asia Chinese)	1	SS
2	921000200464	Lithium charger SS24V8A(Asia English)	1	SS
2	508036510002	Lithium charger 24V8A(ENG)	1	SS
2	508036510003	Lithium charger 24V8A(US、JPN)	1	SS
2	508036510004	Lithium charger 24V8A(EU)	1	SS
2	508036510005	Lithium charger 24V8A(AUS)	1	SS
2	508036510006	Lithium charger 24V8A(ITY)	1	SS
2	508036510007	Lithium charger 24V8A(Sweden)	1	SS
2	508036510008	Lithium charger 24V8A(Israel)	1	SS
2	508036510009	Lithium charger 24V8A(Brazil)	1	SS
2	508036510010	Lithium charger 24V8A(Argentina)	1	SS
2	508036510032	Lithium charger 24V8A(EU)	1	JN
2	508036510033	Lithium charger 24V8A(India)	1	SS
2	508036510035	Lithium charger 24V8A(European style American line)	1	SS
2	508036510036	Lithium charger 24V8A(South Africa)	1	SS
2	508036510040	Lithium charger 24V8A(US)	1	QQE
3	921000200351	Lithium charger SS24V5A(Asia Chinese)	1	SS
3	921000200463	Lithium charger SS24V5A(Asia English)	1	SS
3	508036510025	Lithium charger 24V5A(EU)	1	SS
4	921000200363	Lithium charger QE24V12A	1	QQE
5	921000200353	Lithium charger SS24V8A(Asia	1	SS

		Chinese)		
5	921000200464	Lithium charger SS24V8A(Asia English)	1	SS
5	921000200355	Lithium charger SS24V8A	1	SS(CE)
5	921000200354	Lithium charger SS24V8A	1	SS
5	921000200427	Lithium charger ZJ24V8A(EU)	1	ZJ
5	921000200466	Lithium charger QE24V8A	1	QQE
6	921000200351	Lithium charger SS24V5A(Asia Chinese)	1	SS
6	921000200463	Lithium charger SS24V5A(Asia English)	1	SS
6	921000200418	Lithium charger SS24V5A(EU)	1	SS
7	921500200050	Double end power cord 3x0.75square(Argentina)	1	
7	921500200024	Double end power cord 3x0.75square(AUS)	1	
7	921500200049	Double end power cord 3x0.75square(Brazil)	1	
7	921500200023	Double end power cord 3x0.75square(US)	1	
7	921500200022	Double end power cord 3x0.75square(EU)	1	
7	921500200026	Double end power cord 3x0.75square(Sweden)	1	
7	921500200028	Double end power cord 3x0.75square(Israel)	1	
7	921500200025	Double end power cord 3x0.75square(ITY)	1	
7	921500200047	Double end power cord 3x0.75square(India)	1	
7	921500200027	Double end power cord 3x0.75square(ENG)	1	
7	921500200038	Straight line double 3x0.75square(South Africa)	1	

Fig. 18 Wiring harness

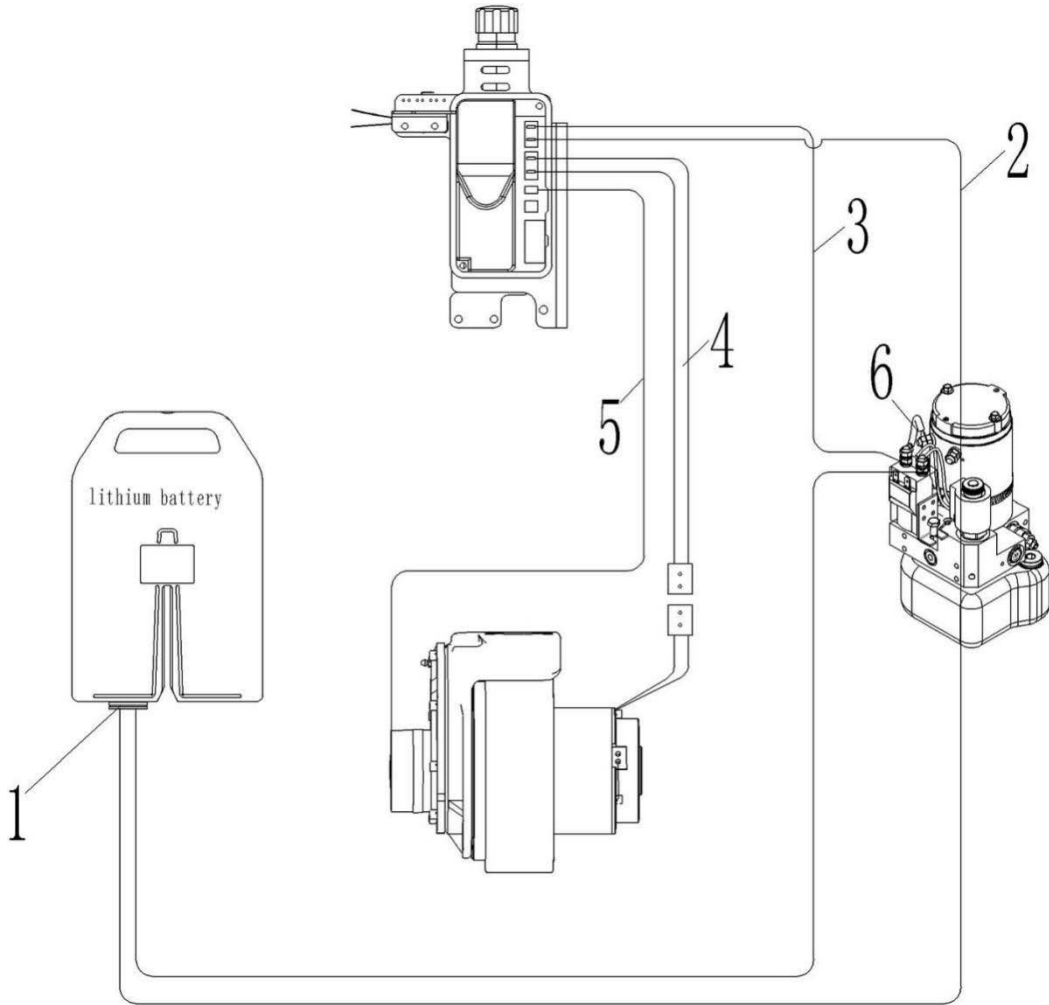

Fig. 18 Wiring Harness

No.	Art No.	Description	Qty.	Note
1	508033010003	Main plug wiring harness	1	
2	508033010004	Controller B+ wiring harness	1	
3	508033010005	Controller B- wiring harness	1	
4	508033010006	Motor main wiring harness	1	
5	508033010007	Brake main wiring harness	1	
6	508033010010	Pump motor B+ wiring harness	1	

Fig. 19 Sticker (EU)

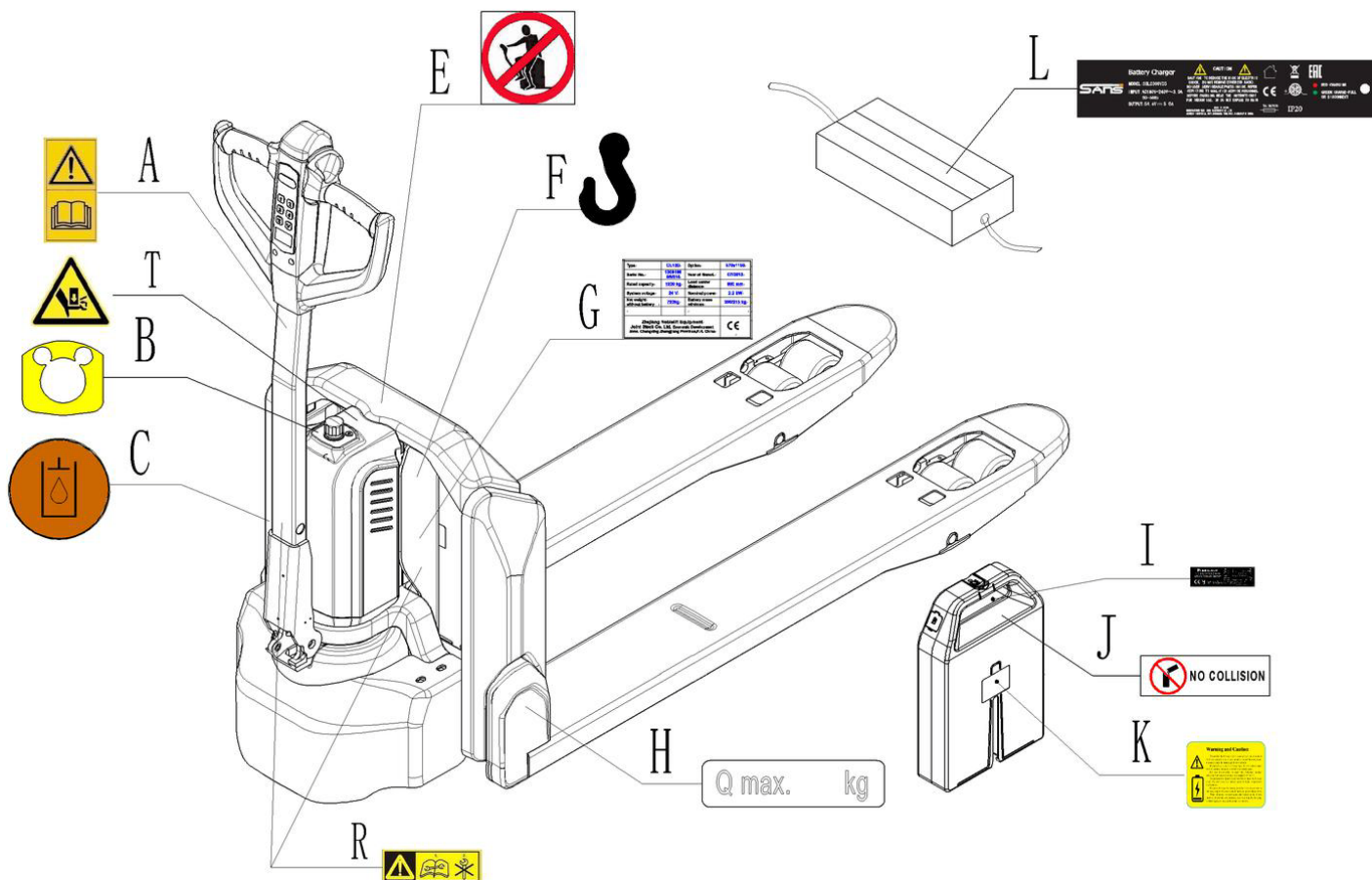

Fig. 19 Sticker (EU)

No.	Art No.	Description	Qty.	Note
A	941200300002	Sticker to read and follow these instructions	1	
B	508047020000	Emergency button sticker	1	
C	941200300003	Sign oil filling point	1	
E	941200100003	"No passengers" decal	1	
F	941200300001	Crane hook label	1	
G	508047520002	Truck identification plate (ID-plate)	1	
H	941200200020	Capacity sticker	1	
I	508047020009	Battery ID plate	1	
J	508047020002	No collision sticker	1	
K	508098520025	Warning sticker	1	
L	508047520005	Charger ID plate	1	
T	508047020007	Warning sticker	1	
R	508047020004	Check service manual	2	

Fig. 20 Sticker (US)

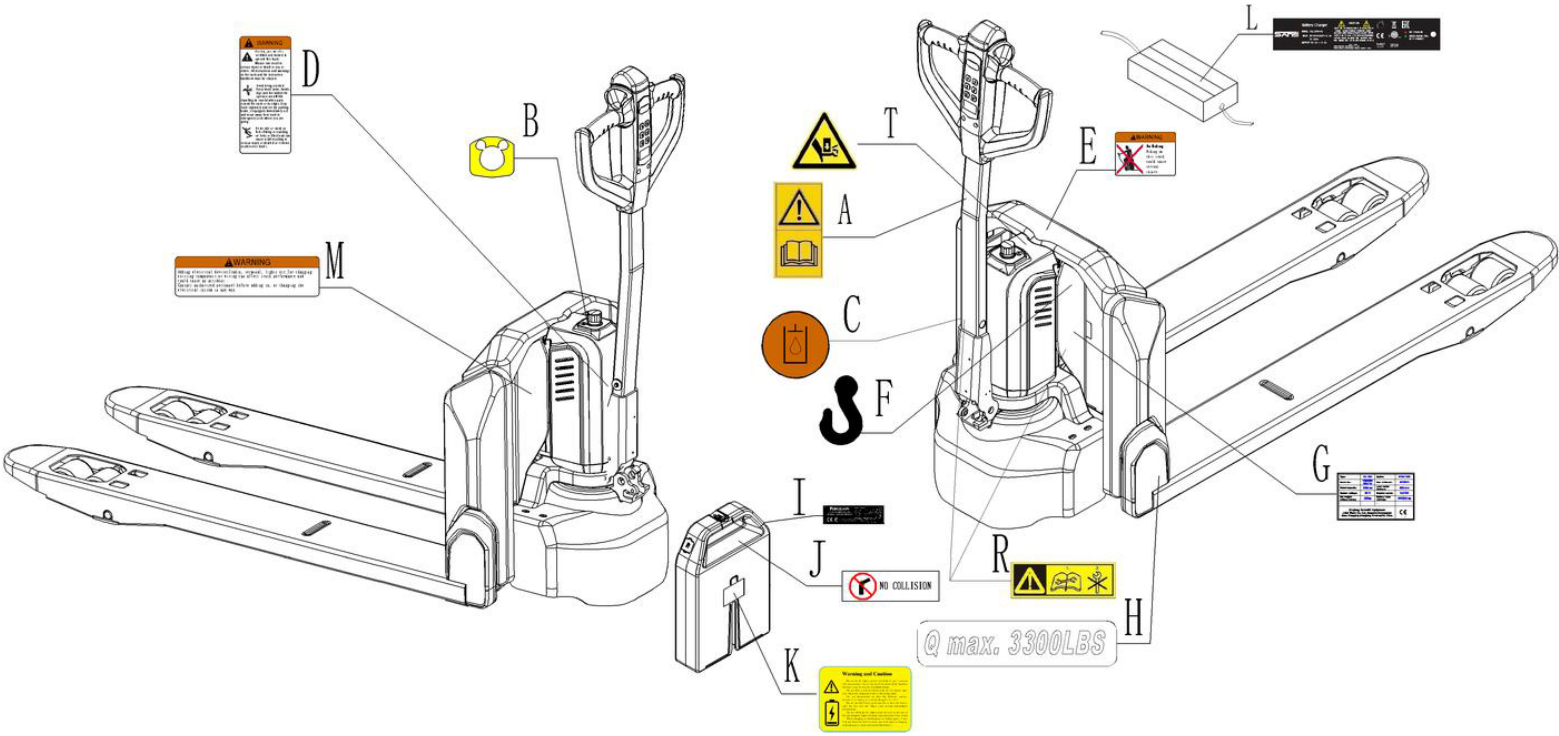

Fig. 20 Sticker (US)

No.	Art No.	Description	Qty.	Note
A	941200300002	Label(Warning Reading)	1	
B	508047020000	(Label) Stop!	1	
C	941200300003	Label(oil injection port)	1	
D	941200100009	Label(Electric Vehicle Portfolio Warning)	1	
E	941200100011	Label(no ride)	1	
F	941200300001	Label(hang point)	1	
G	508047520002	CE Label	1	
H	941200200020	Label(payload 1500 kg)	1	
I	508047020009	Label(battery nameplate)	1	
J	508047020002	Warning Label(Battery)	1	
K	508098520025	Safety warning labels(batteries)	1	
L	508047520005	Label(collision bar)	1	
M	941200100010	Label(No Electrical Modification)	1	
R	508047020004	Label(Warning Reading)	2	
T	508047020007	Label(with hand warning)	1	

Easy worn parts list

No.	Art No.	Description	Qty.	Fig./Position	Note
1	940500100097	Bushing $\Phi 24.6 \times \Phi 29 \times 25$ -SF-1(with oil hole)	2	Fig. 1/4	
2	940500100083	Bushing $\Phi 16 \times \Phi 18 \times 15$ -SF-1(with oil hole)	8	Fig. 1/9	
3	508098510037	Push rod components (800)	2	Fig. 1/16	800
	508098510005	Push rod components (915)			915
	508098510040	Push rod components (1000)			1000
	508098510000	Push rod components (1150)			1150
	508098510041	Push rod components (1220)			1220
4	508098510001	Rock arm components (540)	1	Fig. 1/17	
5	508098510038	Push rod kits (800)	2	Fig. 1/18	800
	508098510006	Push rod kits (915)			915
	508098510043	Push rod kits (1000)			1000
	508098510002	Push rod kits (1150)			1150
	508098510044	Push rod kits (1220)			1220
6	508098510004	Push rod fork components	2	Fig. 1/19	
7	940500100097	Bushing $\Phi 24.6 \times \Phi 29 \times 25$ -SF-1(with oil hole)	4	Fig. 2/4	
8	940500100083	Bushing $\Phi 16 \times \Phi 18 \times 15$ -SF-1(with oil hole)	8	Fig. 2/8	
9	508098510003	Rock arm components (685)	1	Fig. 2/16	
10	508098510037	Push rod components (800)	2	Fig. 2/17	800
	508098510005	Push rod components (915)			915
	508098510040	Push rod components (1000)			1000
	508098510000	Push rod components (1150)			1150
	508098510041	Push rod components (1220)			1220
11	508098510038	Push rod kits (800)	2	Fig. 2/18	800
	508098510006	Push rod kits (915)			915
	508098510043	Push rod kits (1000)			1000
	508098510002	Push rod kits (1150)			1150
	508098510044	Push rod kits (1220)			1220
12	508098510004	Push rod fork components	2	Fig. 2/19	

13	910700200019	Bearing GB276-6204-2RS	8/4(Tandem /Single)	Fig. 3/4	
14	940300300005	Roller Φ 80x70 (Steel core PU)	4(Tandem)	Fig. 3/5	
15	940300300023	Roller Φ 80x93 (Steel core PU)	2(Single)	Fig. 3/10	
16	940500200038	Bushing (With shoulder) Φ 18x Φ 20x12-SF-1(with oil hole)	4 (Tandem)	Fig. 3/11	
17	940500100088	Bushing Φ 20x Φ 22x12-SF-1(with oil hole)	4	Fig. 3/12	
18	502398510014	Wheel set accessories(single)	2	Fig. 3/13	
19	502398510003	Roller kit	2	Fig. 3/14	
20	508098510049	Wheel accessories(double)	2	Fig. 3/15	
21	508098510050	Wheel accessories(single)	2	Fig. 3/16	
22	508098510051	Force Arm Block Component(Double Wheel)	2	Fig. 3/17	Low profile
23	502398510002	Wheel set accessories(double)	4	Fig. 3/18	
24	910700200058	Bearing GB276-6013-2RS	1	Fig. 4/4	
25	910700600044	Bearing GB297-32913	1	Fig. 4/6	
26	910800100098	O ring	1	Fig. 6/2	13.5x1.8
27	910800800003	antiextrusion ring 12.7x9.8x1.25	1	Fig 6/7	
28	910800100001	O-ring - within 9.5x1.8	1	Fig 6/8	
29	508598510004	Sealed assembly	1	Fig 6/9	
30	508598510004	Sealed assembly	1	Fig 8/9	
31	508098510054	Hydraulic assemblies	1	Fig 8/10	
32	910700200018	Bearing GB276-6203-2RS	2	Fig. 9/3	
33	940300300017	Roller Φ 80x30(Steel core PU)	1	Fig. 9/4	
34	508016510005	Balance Wheel Component Φ 80x30 (PU / right)	1	Fig. 9/5	
35	502398510015	Roller components	1	Fig. 9/6	
36	508098510047	Spring components	1	Fig. 9/7	
37	508016510002	Balance Wheel Component Φ 80x30 (PU /left)	1	Fig. 9/10	
38	940500200001	Bushing (With shoulder) Φ 15x Φ 17x9-SF-1	2	Fig. 12/12	
39	920100200002	Fuse 10A	1	Fig 13/22	
40	920100200006	Fuse 7A	1	Fig 14/2	