

SUPERBUILD

MODULAR STEEL STORAGE SYSTEMS



METALISTEM[®]

METALSISTEM

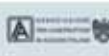

FEM section X

METALSISTEM



38068 Rovereto (TN) - Italy - Viale dell'Industria, 2 - Tel. 0039 0464 303030 - Fax 0039 0464 303031
e-mail: info@metalsistem.com - Internet: www.metalsistem.com



FEM section X

AZIENDE GRUPPO METALSISTEM / METALSISTEM GROUP MEMBERS

SERVIZIO / SERVICE



55 West Beaver Creek Road, Unit #7
Richmond Hill - Ontario - L4B 1K5 - CANADA
Tel. 001 905 8899499
Fax 001 905 8866890
info@metalsistemcanada.com
www.metalsistemcanada.com



P. O. Box 91
Nodrie VIC 3042 - AUSTRALIA
Tel. +61 3 944 97588
Fax +61 3 944 97622
info@metalsistemaustralia.com
www.metalsistemaustralia.com



Philadelphia, Pennsylvania (PA)
Office and Showroom:
428 North 2nd St. Philadelphia, PA 19123 USA
Tel: 215-430-0730 Fax: 215-430-0731
Warehouse:
3201 Fox St. Philadelphia, PA 19129 USA
Miami, Florida (FL)
2101 W. Atlantic Blvd. Unit 110,
Pompano Beach, FL 33069
info@metalsistemnorthamerica.com
www.metalsistemnorthamerica.com
Toll Free phone number 1-866-412-4558



Rue de l'Industrie, 21
L 5399 Windhof - LUXEMBOURG
Tel. +352 397205
Fax +352 399230
info@luxmetalsistem.lu
www.luxmetalsistem.lu



Galleisstraat, 20
1704 SE Heerhugowaard - Nederland
Tel. 0031 72 5760165
Fax 0031 72 5760169



Via Industria
06814 Lamone - Canton Ticino
SWITZERLAND
info@metalsistemtecnologic.com
www.metalsistemtecnologic.com



63033 Montoponese
Centobuchi (AP) Italy
Via dei Lavori, 16
Tel. 0735 704880
Fax 0735 710413
info@blocksystem.it



80144 S. Pietro a Paterno (NA) Italy
Via Caserta al Bravo, 192
Tel. 081 7385602
Fax 081 7385664
info@logsystem.it



38068 Rovereto (TN) Italy
Viale del Lavoro, 3
Tel. 0464 43 88 96
Fax 0464 43 73 66
info@metalsistemnord.it



60028 Osimo Stazione (AN) Italy
Via Maestri del Lavoro, 17
Tel. 071 710 86 50
Fax 071 710 84 85
metalsim@tin.it
www.metalsistemmarche.it



41012 Carpi (MO) Italy
Via C. Manz. 113
Tel. 059 696 450
Fax 059 642 479
info@metalsistememilia.it
www.metalsistememilia.it



20090 Buccinasco (MI) Italy
Via E. Fermi, 6
Tel. 02 45708646
Fax 02 45708647
info@metalsistemlombardia.it



33080 Cusano di Zoppola (PI) Italy
Via Elero, 11/A
Tel. 0434 97 0 77
Fax 0434 97 1 77
info@metalsistemtoscana.it



07100 Sassari (SS) Italy
Z.I. Predda Niedda Nord, str. n. 3
Tel. 079 260 559
Fax 079 263 3604
info.metsardegna@metalsistem.com
www.metalsistem Sardegna.com



00040 Pomezia (RM) Italy
Via dei Castelli Romani, 56/58
Tel. 06 91801333
Fax 06 91621141
info@metalsistemroma.it



37060 Caselle
di Sommacampagna (VR) Italy
Via dell'Artigianato, 24
Tel. 045 858 12 12
Fax 045 858 11 66
info@vierreistem.it



91220 La Plessis Paté France
11, Rue Léonard de Vinci - Z.I. du Parc
Tel. +33 1 69 88 82 82
Fax +33 1 69 88 83 83
france.rayonnages@wanadoo.fr



90142 Palermo (PA) Italy
Via Brigata Aosta, 58/60/62
Tel. 091 382 316 / 547 674
Fax 091 637 45 43
glstem@inwind.it



10028 Trofarello (TO) Italy
Via Torricelli, 39
Tel. 011 649 75 89
Fax 011 649 84 89
info@metalsistempiemonte.com



06037 Foligno (PG) Italy
Via dell'Industria
Loc. Fioroni di S. Eracleo
Tel. 0742 39 16 34
Fax 0742 39 36 55
info@metalsistemumbria.it
www.metalsistemumbria.it



50041 Calciano (FI) Italy
Via del Prigioniero, 80
Tel. 055 887 36 33
Fax 055 887 46 52
info@soteasistem.com
www.soteasistem.com



40026 Imola (BO) Italy
Via Ferrara, 4A
Tel. 0542 64 39 81
Fax 0542 64 38 52
info.metromagna@metalsistem.com



25010 Loc. Foltano (BS) Italy
Via Tito Saresani, 13/15
Tel. 030 260598
Fax 030 2160301
info@tecnosistem.it



35011 Campodarsego (PD) Italy
Via Antoniana, 286
Tel. 049 5201417
Fax 049 5564755
info@centrometalsistem.it



91220 La Plessis Paté PARIS France
11, Rue Léonard de Vinci - Z.I. Du Parc
Tel. +33 1 69 85 16 45
Fax +33 1 69 84 95 54
info@sidac-evolution.net



Nottingham NG2 1LW ENGLAND
Crossgate Drive, Queens Drive Industrial Estate.
Tel. +44 115 8500162
Fax +44 115 8500163
equipmen@metalsistem.com



08110 Morcada 1 Reixac BARCELONA Spain
C/Narcís Monturiol n°4 nave 14
Tel. +34 935 651 800
Fax +34 935 651 801
sidac-iberia@sidac-iberia.com

PRODUZIONE / PRODUCTION



38068 Rovereto (TN) Italy
Viale dell'Industria, 2
Tel. 0464 30 30 30
Fax 0464 30 30 31
info@metalsistem.com
www.metalsistem.com



25064 Gussago (BS) Italy
Via Mandolossa, 100
Tel. 030 25 26 511
Fax 030 25 26 500
info@sidac.net



38068 Rovereto (TN) Italy
Via Caproni, 3/B
Tel. 0464 421 505
Fax 0464 487 266
info@galtre.it



O.S. Kredit
Slavkov 294
CZ - 667 64 okr. Uherske Hradiste
CZECH REPUBLIC
Tel. +420 572 648615
Fax +420 572 648071
obchod@kredit.cz
www.kredit.cz



70017 Pulignano (BA) Italy
Via Maestri del Lavoro n.c. - Z.I.
Tel. 080 405 41 54
Fax 080 405 41 43
info@smetar.it
www.smetar.it



21013 Gallarate (VA) Italy
Via Monte Leone, 25
Tel. 0331 79 36 19
Fax 0331 77 04 07
luoni@metalsistem.com



20017 Mazzo di Rho (MI) Italy
Via G. di Vittorio, 7/29
Tel. 02 939 00 759
Fax 02 939 00 838
csamagazini@libero.it



38068 Rovereto (TN) Italy
Viale dell'Industria, 2
Tel. 0464 438 538
Fax 0464 438 998
i@ideainformatica.com



35011 Campodarsego (PD) Italy
Via Antoniana, 286
Tel. 049 55 66 136
Fax 049 55 66 137
info@metalsistempoint.it

THE GROUP

Founded in 1968, METALSISTEM commenced its activities specialising in the design and production of machinery for the cold profiling of metals. The experience gathered, numerous highly innovative patents resulting from intense research and development and the considerable market success of the first range of cold form zinc coated profiles quickly channelled METALSISTEM into the production of the latter of its activities.

Today the METALSISTEM Group is an articulated network of companies with its head office and main production facility in Rovereto, Italy. The Group has consolidated its position as one of the major industries within the Material Handling Sector.

Through products and services aimed at providing complete assistance for all warehousing, product showcasing and sales outlet requirements, the companies of the METALSISTEM Group are able to offer their customers a wide range of products of the highest quality, highly competitively priced, with very rapid delivery times and a first class back up service, as well as tailor made solutions providing efficient and rational use of internal storage areas and material handling environments. Lightness, strength and modular form, coupled with the ease of integrating and expanding already existing structures are but a few of the successful features of the METALSISTEM storage and shelving systems.

The success of the METALSISTEM Group is the result of a precise managerial choice based on research of new production technologies and continuous development and innovation of its product range. A direction which has produced numerous international patents (testament to the uniqueness of the METALSISTEM product), continuing improvements in safety, quality and versatility.

METALSISTEM's company strategy is to offer products of the highest quality, very competitively priced, with rapid delivery times backed up by a first class service.

The numerous product lines are conceived and designed by METALSISTEM's internal Research and Development Centre, as are the profiling lines and equipment required for their manufacture.

The automated production facilities for the cold profiling of metals have enabled METALSISTEM to achieve one of the highest levels of productivity in the world, today. Rigorous laboratory tests are conducted on the prime material entering production, and on the final product, thus ensuring the continuing evolution of efficiency and quality standards.

All products have elevated structural characteristics and ensure high quality standards recognised by the most important European certification bodies, such as Germany's TÜV Product Service GmbH, Austria's Ö-NORM, Rome's I.S.P.E.S.L., ACAI/CISI (Associazione Costruttori Acciaio Italiani - Sezione Costruttori Italiani di Scaffalatura Industriale), the latter of which METALSISTEM has membership, and others. The company's ISO 9001 quality assurance system is certified by IGQ. With an annual turnover of exceeding 260 Million Euro, the METALSISTEM Group premises occupy a total area of 200.000 m², 120.000 of which are dedicated to production. The METALSISTEM Group affiliated companies and distributors provide a world wide commercial network covering the domestic market and the industrialised nations of the world, able to satisfy the most demanding needs.

We value greatly the high level of trust that is placed in us by our customers and feel that it is proof of the quality and reliability of our products.



SAFETY STANDARDS AND CALCULATION ASSUMPTIONS

The correct use of a product, distinguishes both the Customer and the Manufacturer. METALSISTEM recommends that Customers make use of their product in strict conformity with the design characteristics given and standards of best practice. The design and assembly of the racking systems must be carried out by qualified personnel. METALSISTEM is not responsible for any improper or inappropriate use of its product.

Ref. no:	SUPERBUILD 145
System:	1998
Year of Construction:	12500 Kg
Frame Load Capacity:	2500 kg
Load Capacity of Beams:	800 kg
Weight of Load Unit:	m.1 N° levels: 5
Distance between ground and first level:	

fig. 2

a) Floor slab loading.

Prior to installation of the product, check that the floor slab is of adequate load capacity.

b) Site installation.

The site installation of racking systems must be carried out by expert personnel following the assembly criteria and specifications tabled in this catalogue and in the SUPERBUILD Technical Reference Book. Site personnel must ensure that all frame bolts have been tightened and all safety elements have been installed.

c) Rack alignment.

While assembling the racking system, the verticality of the frames must be checked for both the "X" and "Z" directions. Unless more restrictive standards have been specified, the deviation of both the "X" and "Z" planes must not exceed \pm



fig. 1

10 mm or 1/350 of the height (ie max.deviation = H/350), whichever is greater (figure 1).

d) Load bearing capacity plate.

Load bearing capacity plates must be fastened in a clearly visible position nominating the model type, year of assembly, load bearing capacity of the frames, load bearing capacity per pair of beams or per shelf (expressed as a uniformly distributed load), the load unit applied, the height of the first level from ground and the number of levels (figure 2).

e) Rack safety standard.

Rack structures must be fastened to the floor slab via two anchor bolts for every upright.

In cases where the height of the frame is:

- more than 5 times the depth, for single-sided racking;
- or, more than 10 times the depth, for double-sided racking;

that structure must be connected via top ties.

The racking structure must also be supplied complete with column and/or frame protectors.

f) Reference Standards.

The theoretical calculation is based on the following reference standards:

- C.N.R. 10011/88
- C.N.R. 10022/84

Reference standards for the materials are:

- EN 10142
- EN 10147
- EN 10204

g) Software references.

The theoretical calculations of finished elements were elaborated with the SICS program. Guide lines followed as the basis for the calculations are those of the organisation CISI (Association of Italian Manufacturers of Industrial Shelving).

h) Frame load bearing capacity.

The load bearing capacity graph (Graph 1) in the SUPERBUILD Technical Reference Book shows the load bearing capacity of frames used for pallet racking systems. These are expressed as a function of the height, from ground, of the first pair of beams. The following underlying assumptions apply when interpreting the graph. The racking has:

- a minimum of 4 consecutive bays of equal length;
- a minimum of 3 levels divided equally in height;
- an equal and uniformly distributed load has been applied to all levels.

Given that the load bearing capacity of the rack may depend on other elements such as, the number of levels, the proportion between height and depth, installation in seismic areas, etc., contact the METALSISTEM Technical Department for consultation should there be doubts about any aspects of the installation.

i) Load bearing capacity of beam pairs.

The load bearing capacity of the beam pairs were calculated with the following assumptions:

- loads are uniformly distributed;
- admissible tensile stress of the material;
- deflection 1/200.

It is mandatory to place beam retaining security clips on either side of all beams.

l) Custom built applications

The METALSISTEM Technical Department is at the disposal of its customers for any specific calculations or custom built applications.

METALSISTEM reserves the right to modify the technical characteristics of its products at any time as it sees fit.

Technical data, dimensions and characteristics given in this document are indicative only.

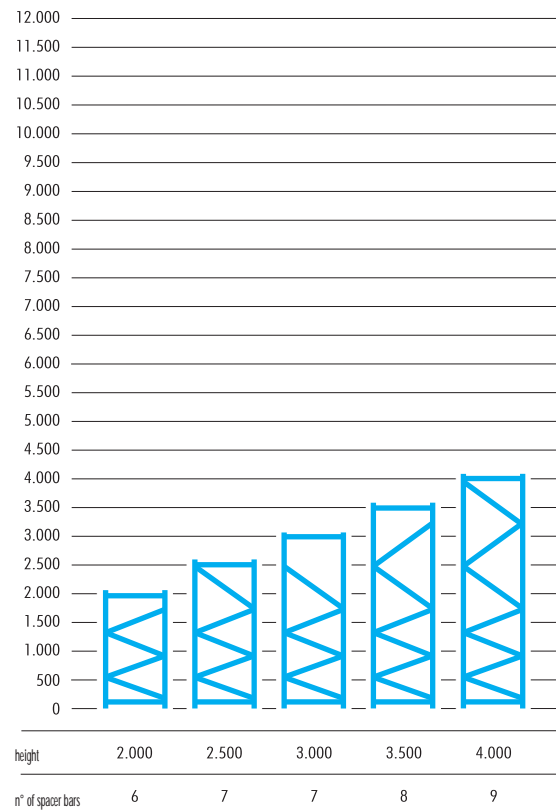
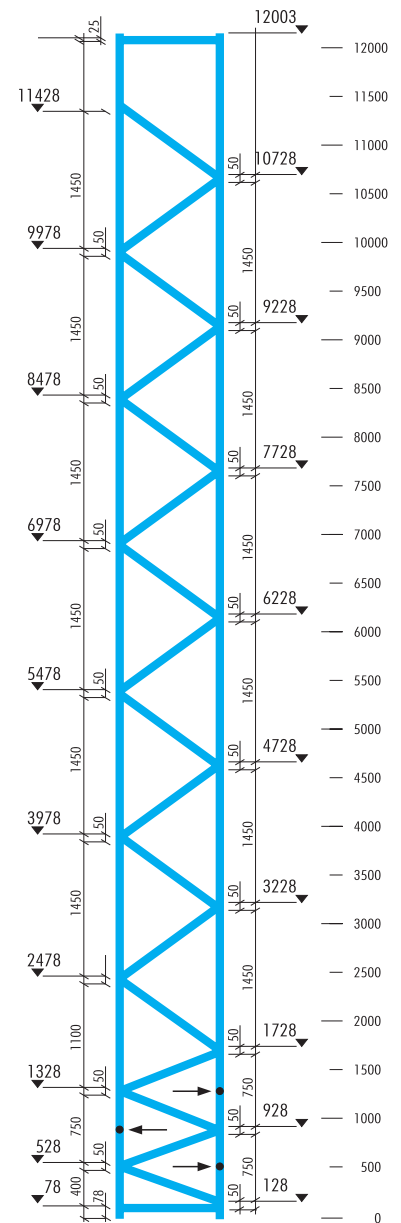
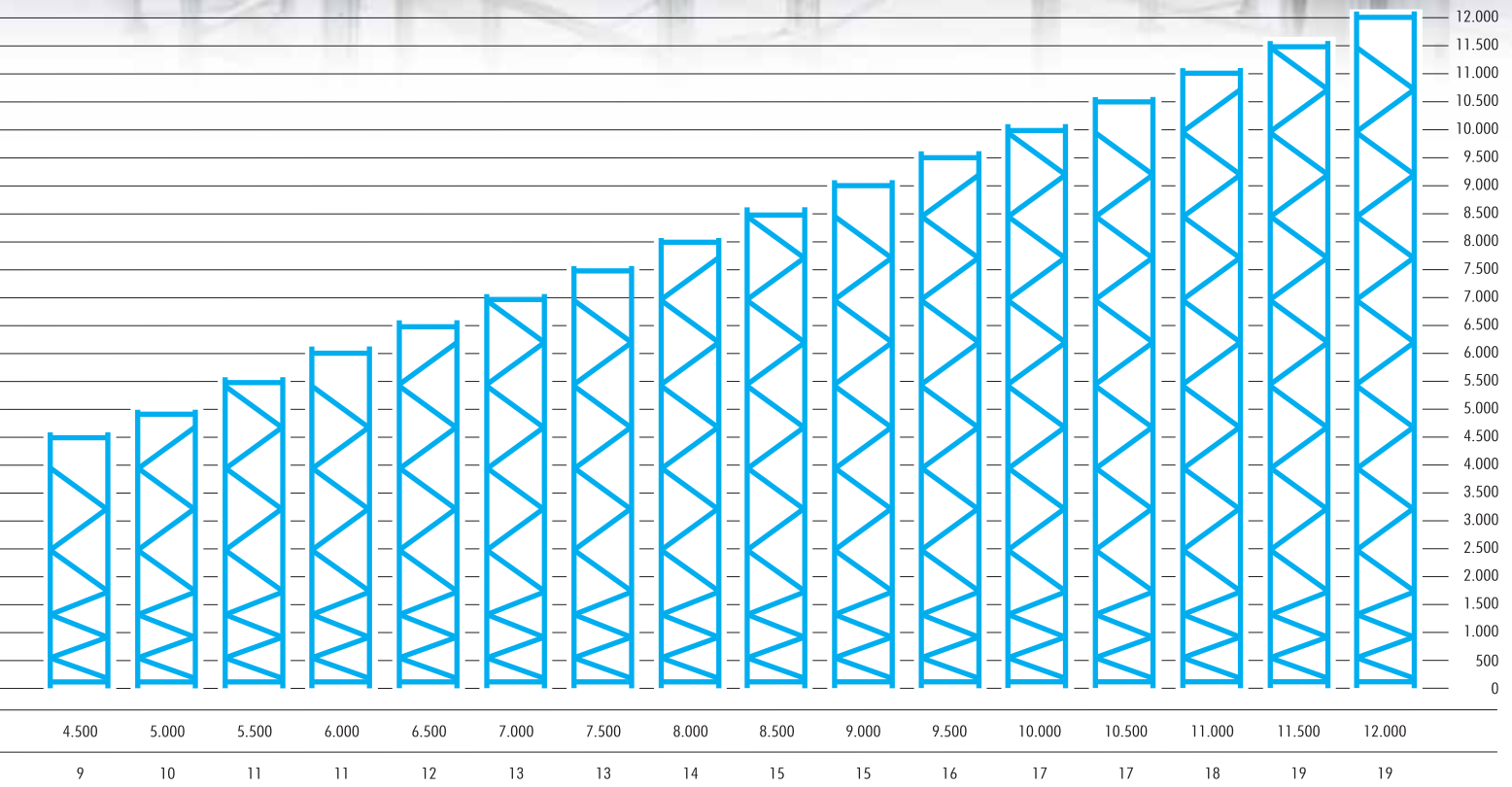

DIAGRAM FOR ASSEMBLING BRACING OF SUPERBUILD FRAMES

SUPERBUILD systems are made from high tensile steel, certified according to EN 10204 3.1B and carry the approval mark of TÜV PRODUCT SERVICE GmbH.



To achieve the stated frame load bearing capacities, frames should be built in strict accordance with the assembly diagram above. Three bolts 8x20 mm should be placed opposite to the short diagonal crossings, respectively at the height of 528, 928 and 1328 mm, as shown on the left.

THE COMPANY TODAY

METALSISTEM products are now in use in a great many installations throughout the world, and after more than 30 years production, we value greatly the high level of trust that is placed in us by our customers and feel that it is proof of the quality of our products. The shelving components are produced on fully automated production lines. The folding and cold processing techniques developed by METALSISTEM are designed to obtain light and extremely strong components. Lightness, strength and modular form, coupled with the ease of integrating and expanding already existing structures are but a few of the successful features of the METALSISTEM Industrial Storage Systems. Ideal storage solutions for a whole host of products supplied worldwide are created here thanks to a total commitment to research and development. The METALSISTEM Technical Department is at the complete disposal of its customers, to study their individual needs and to propose the most effective solutions.







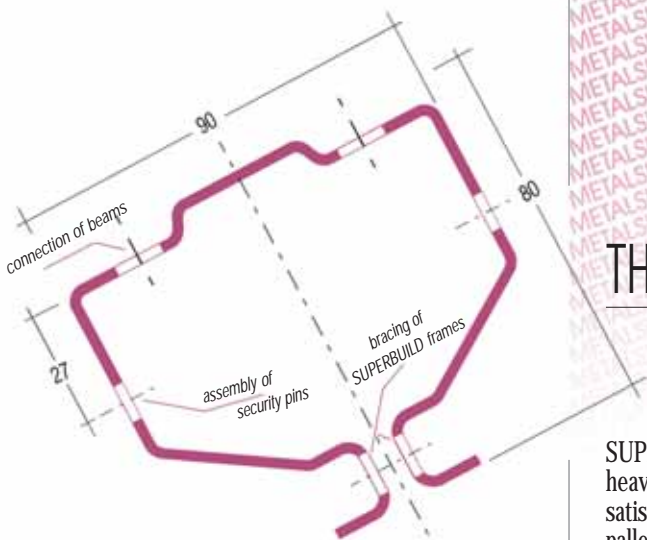

THE PRODUCT

SUPERBUILD is interchangeable with the UNIBUILD heavy duty pallet racking and has been designed to satisfy all the requirements of medium to heavy duty pallet storage.

It is available in three different frame load options, varying from 7.5 up to 15 tons.

The closed design of the frame upright provides a stronger section than that of the standard open "C" profiles used by other manufacturers.

The frames are made from prime quality, certified, high tensile hot dipped galvanised steel (procedure SENDZIMIR), thus ensuring a high level of durability. All the structural components are made from high tensile steel, certified according to EN 10204 3.1B.

The beams are profiled sections with quadruple flange thickness at points of maximum stress for high loading capability. The grooves on top of the beams are used to locate modular heavy duty steel shelf panels, pallet support bars and drum cradles for the storage of non palletised or special goods.

The welded beam end connector has five anchor points, three of them operating in tension and two in compression, providing a better connection to the upright with increased load capability.

The adjustment of beams at intervals of 50 mm facilitates optimum use of space available.

The beams are painted in yellow RAL 1004 (standard colour) according to the following procedure:

- hot wash degreasing and iron phosphate pretreatment;
- application of thermosetting powder paint.
- curing at a temperature of approx. 240°C in a force ventilated air circulation oven.

The design of the various components is the result of rigorous technical testing and the highly specialised knowledge developed over years of experience in the field of metal processing.

This experience has enabled METALSISTEM to offer innovative products of the highest quality, highly competitively priced, and to produce a highly technical solution to the most important shelving problems, such as rapid assembly, stability, low cost and load bearing capacity.

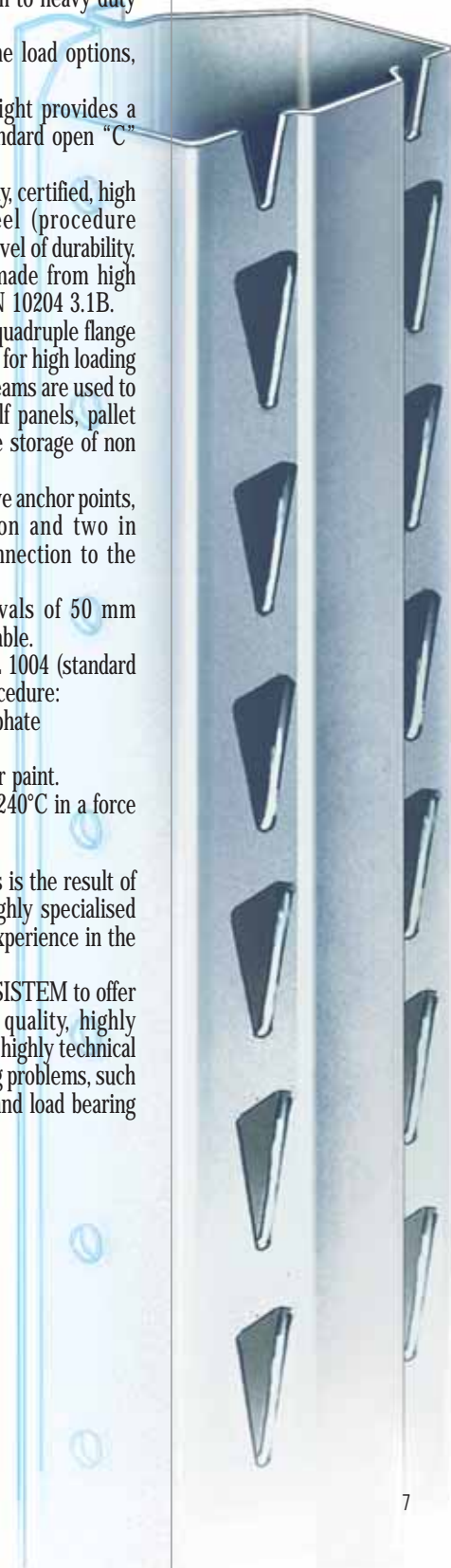
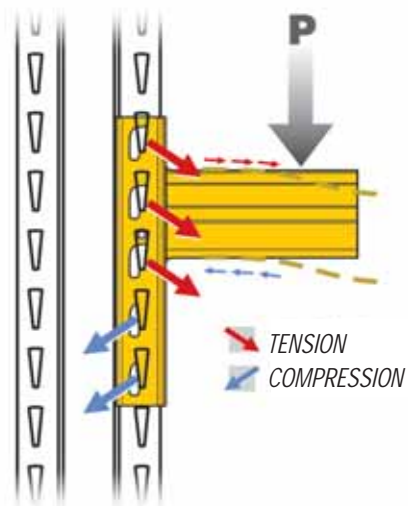
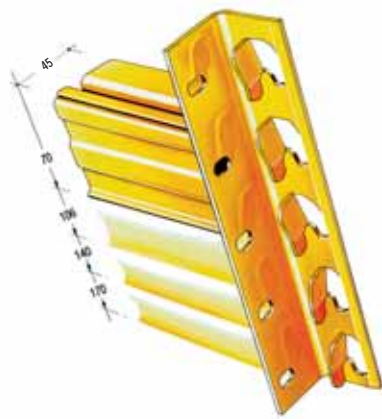
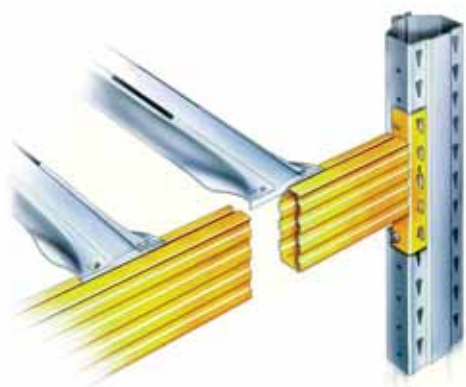

MAIN STRUCTURAL COMPONENTS

The design of the various components is the result of rigorous technical testing and the highly specialised knowledge developed over years of experience in the field of metal processing.

The components are subjected to regular and rigorous technical tests.

The safety and the quality of the product have always been a primary aim of METAL-SISTEM and are recognised by TÜV PRODUCT SERVICE in Munich, one of the most rigorous E.C. commissions in the field of quality and safety certification.

The versatility of METALSISTEM installations makes them suitable for a wide range of applications not illustrated here. METAL-SISTEM offers innovative products of the highest quality, providing highly technical solutions to the most important racking problems, such as rapid assembly, extreme stability and strength and utmost cost efficiency.

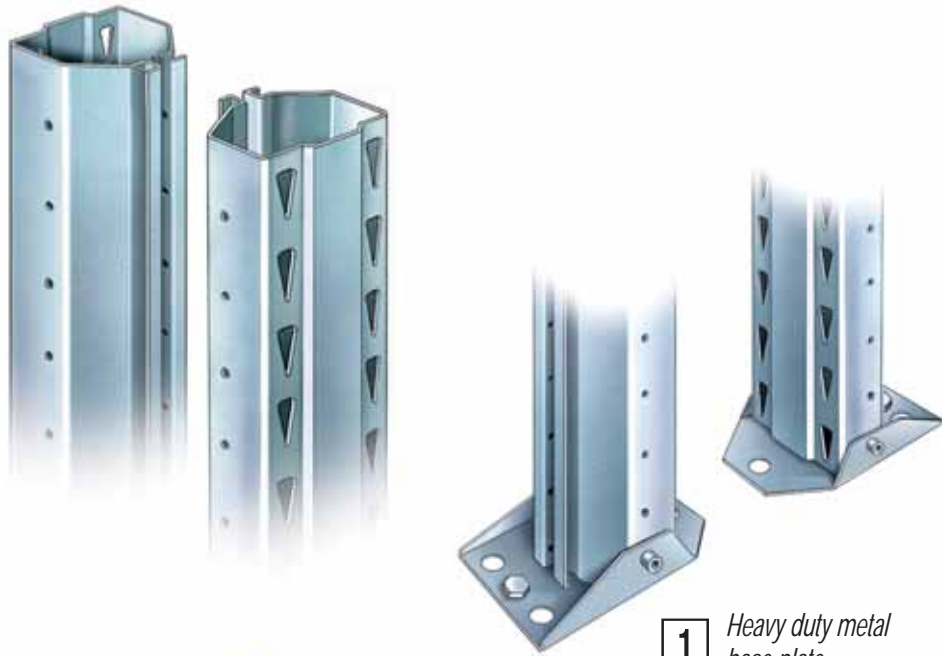

1 Heavy duty metal base plate

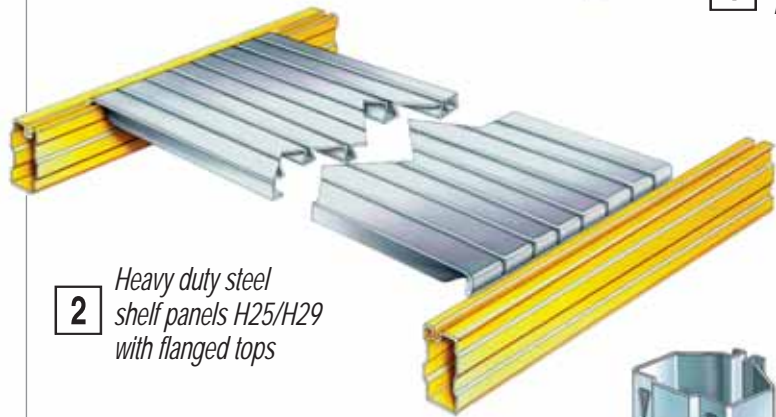

2 Heavy duty steel shelf panels H25/H29 with flanged tops

3 Beams used for pallet racking or for heavy duty steel shelf panels to be inset

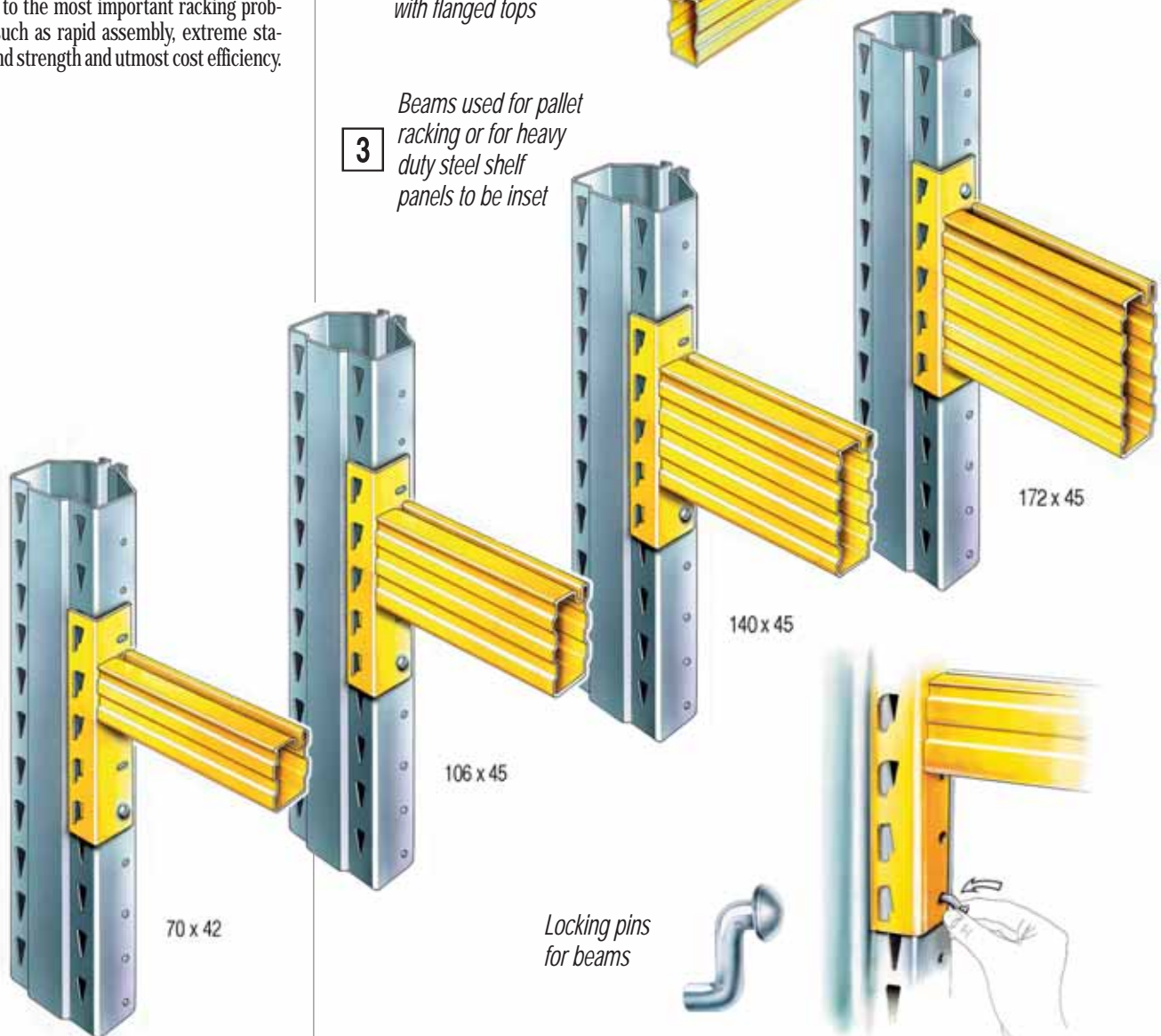

Locking pins for beams



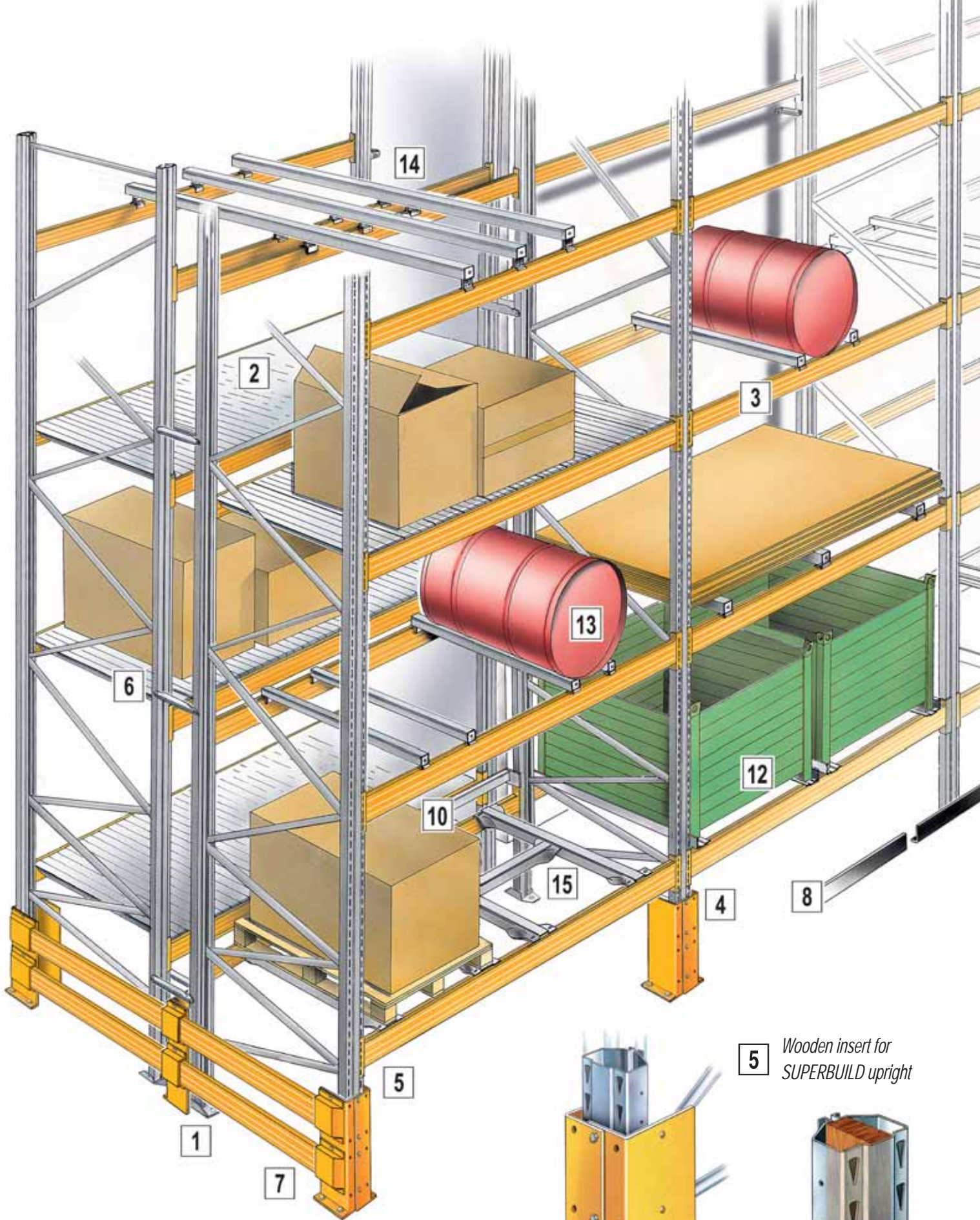

Regarding technical data, characteristics and dimensions, customers should refer to the Technical Reference Book of the SUPERBUILD series.

4
*Column
protector*

5 *Wooden insert for
SUPERBUILD upright*

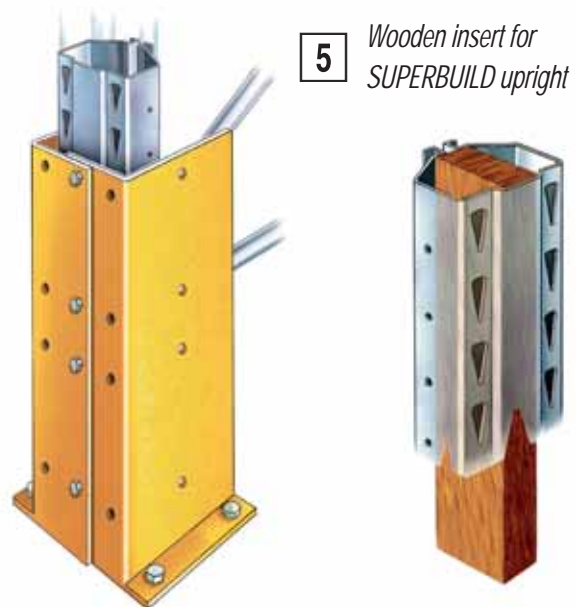

ACCESSORIES

Regarding technical data, characteristics and dimensions, customers should refer to the Technical Reference Book of the SUPERBUILD series.

8

Floor mounted
guide rail
(single and double-sided)

6

Row spacers

9

Load
distribution plate

10

Pallet backstop
beam

11

Double frame
protector
(detail)

7

Double frame
protector

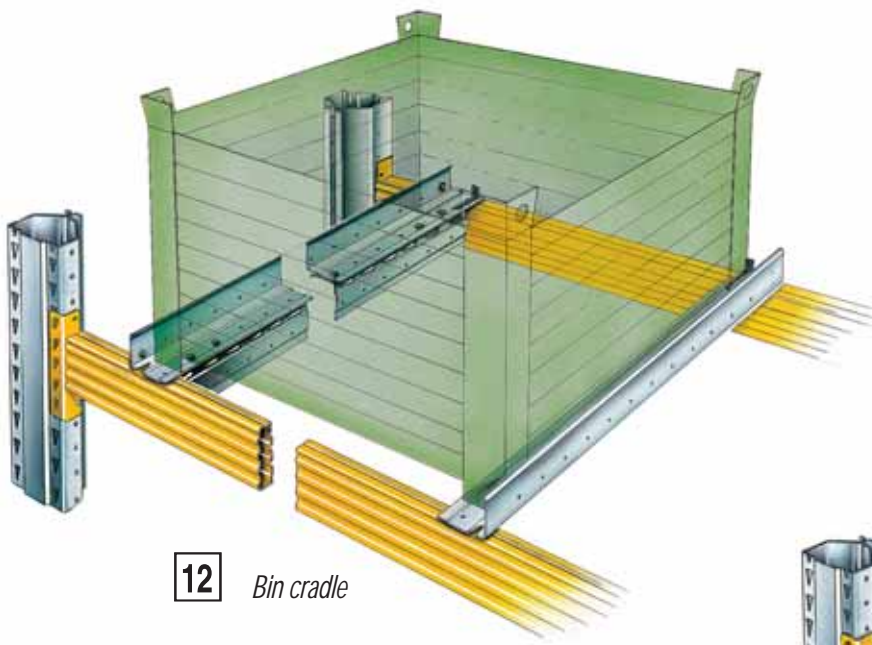

12 Bin cradle

13 Drum cradle
Drum wedges

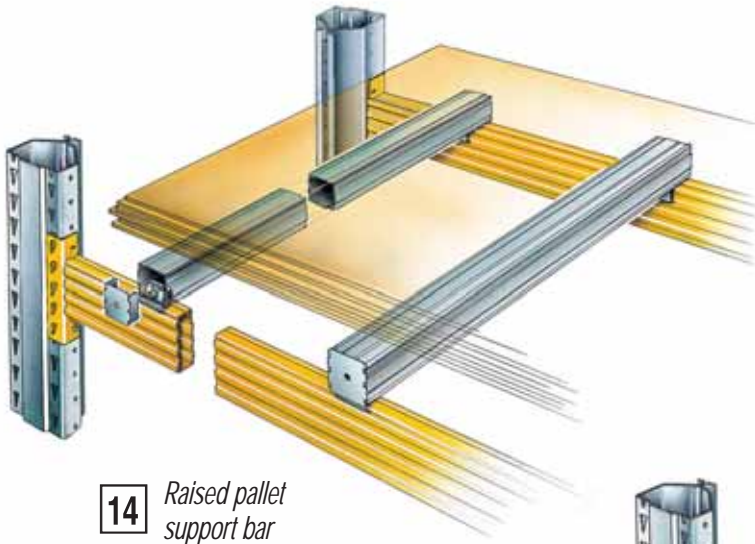
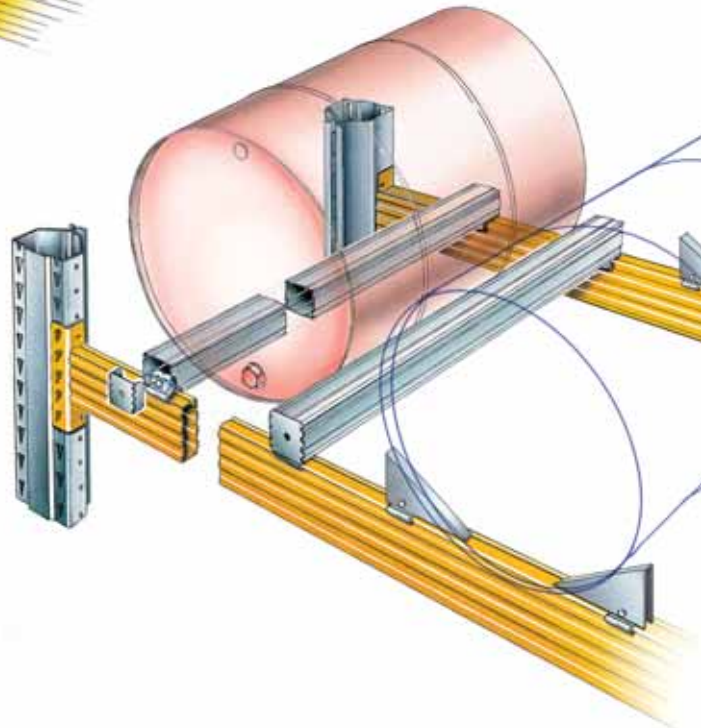

14 Raised pallet support bar

15 Combined pallet support bars

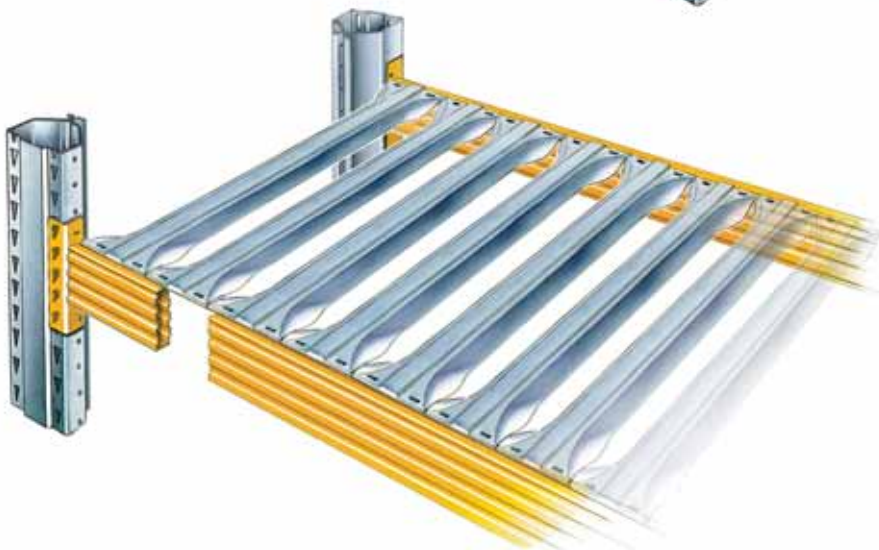
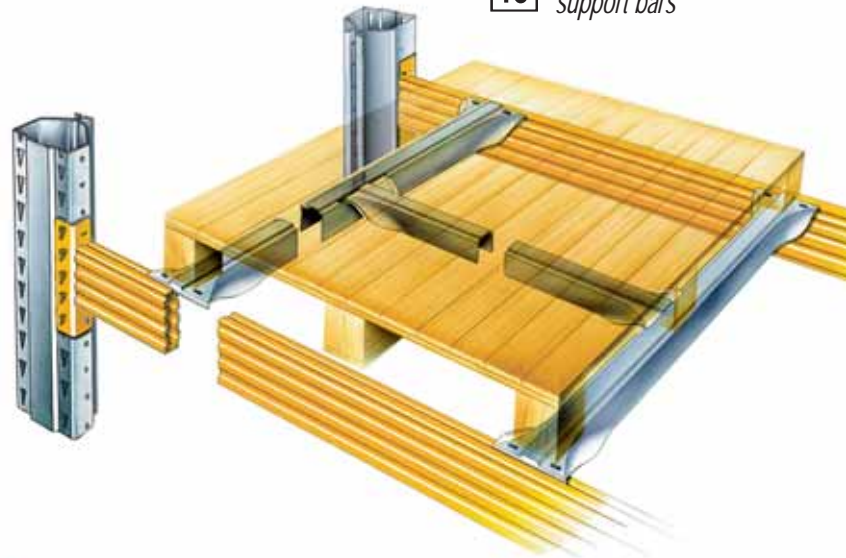

16 Lightened secondary beams
For use in installations equipped with
sprinkler systems (shelf surface
with coverage < 50%)



18 Entrance crescent for DRIVE IN guide rail

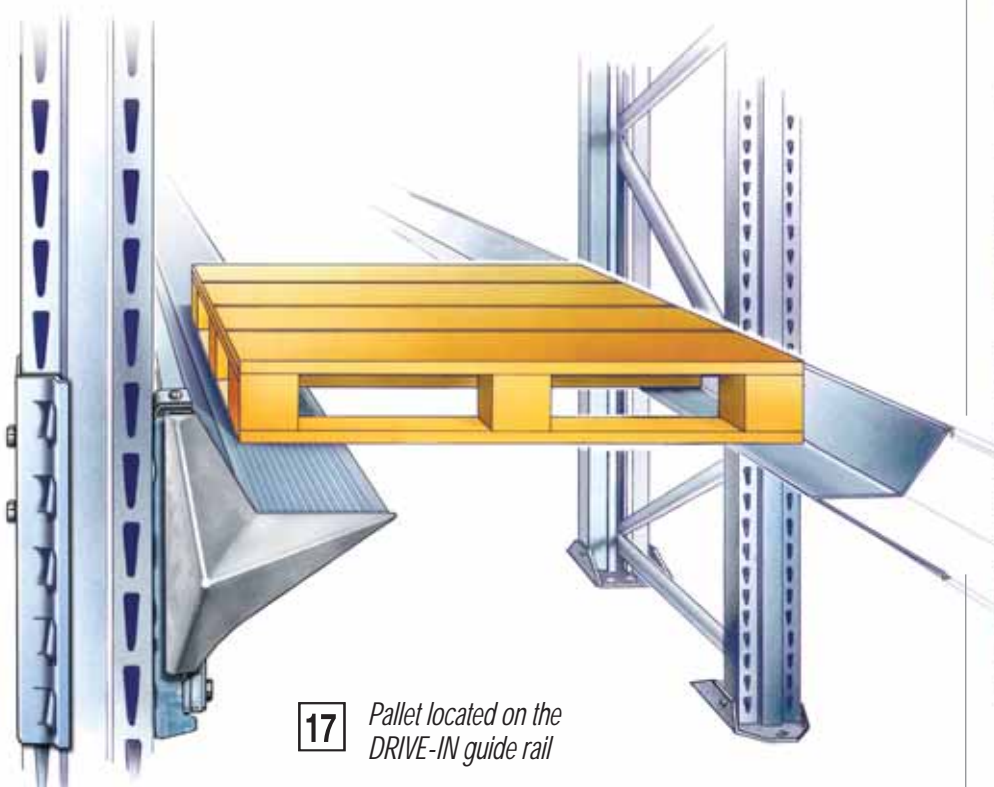

17 Pallet located on the DRIVE-IN guide rail

DRIVE - IN

The DRIVE-IN racking system allows the maximum use of space, and volume due to the elimination of access aisles. The storage volume is therefore more than doubled compared with standard pallet racking. Two kinds of installation are possible: DRIVE-IN or DRIVE-THROUGH.





For a correct assembly of DRIVE-IN structures, customers should always refer to the DRIVE-IN Assembly Instructions.

20 DRIVE-IN guide rail located on a single bracket

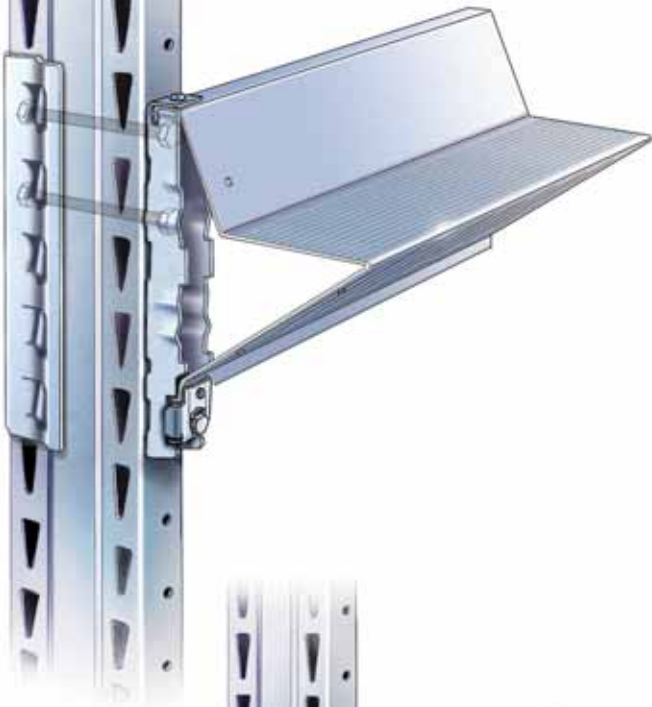

19 DRIVE-IN guide rail located on a double bracket

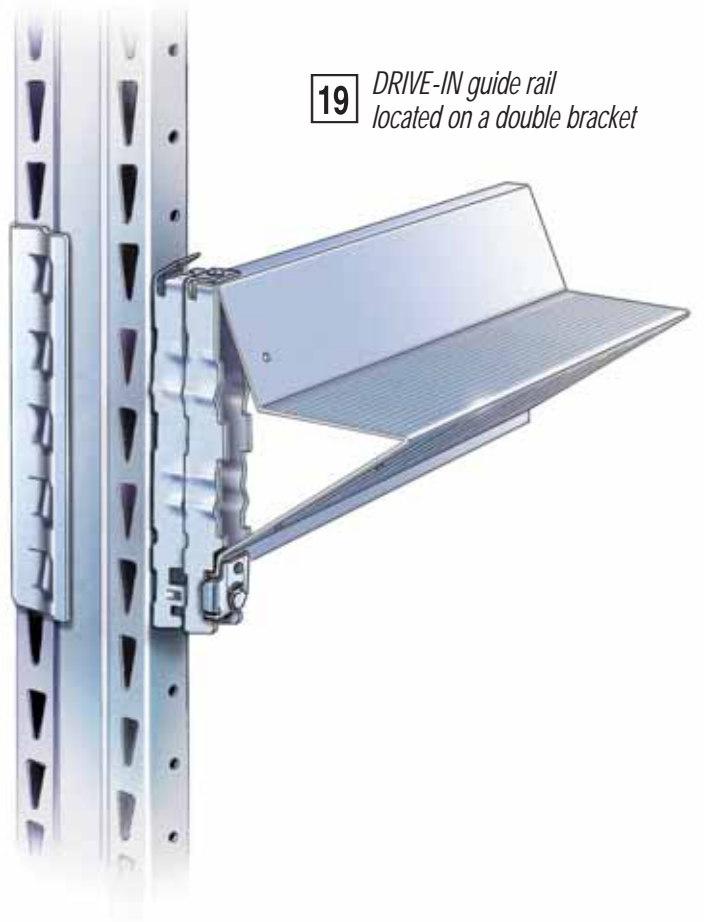

21 Entrance crescent for DRIVE-IN guide rail (detail)

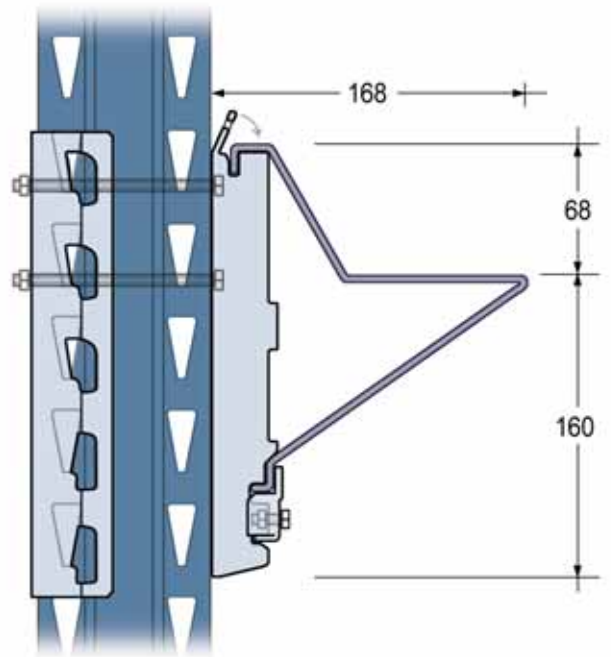

22 Double sided DRIVE-IN guide rails located on single brackets.





SUPERBUILD

New.
Strong.
SUPER!

■ METALSISTEM...
we don't speak about
the future...
we make it.



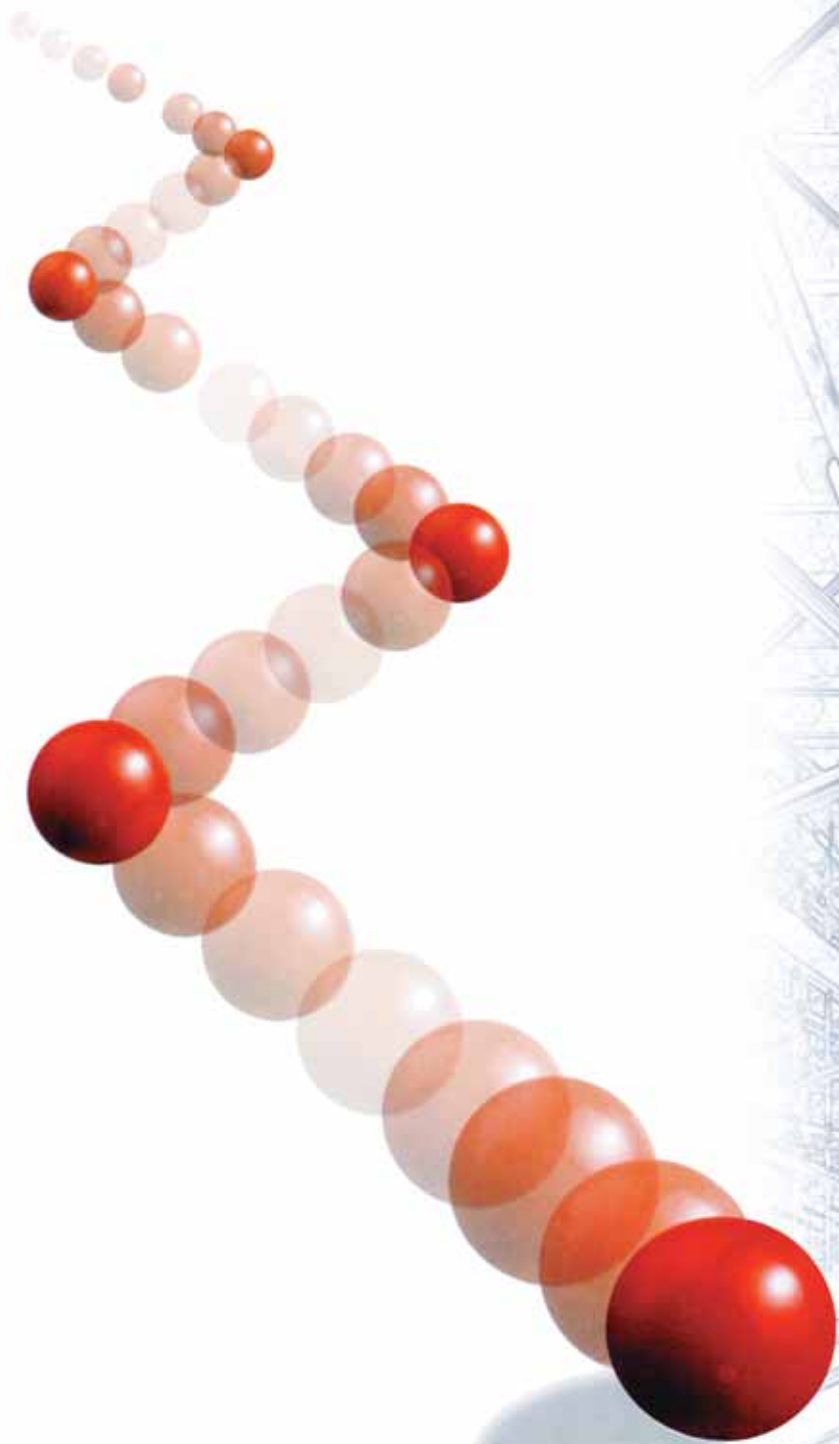

...in Space and Time Metalsistem.

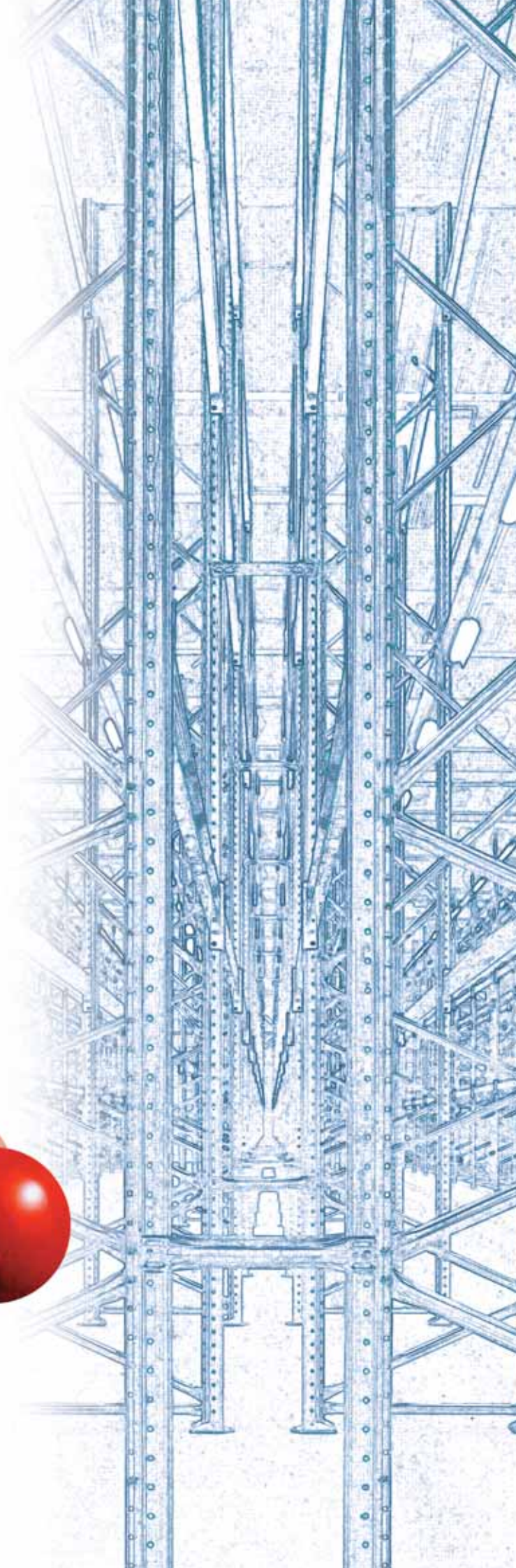



METALSISTEM®

SISTEMI E STRUTTURE PER IL MAGAZZINO



METALSISTEM®

METALSISTEM S.p.A.
 38068 Rovereto (TN) - Italy - Viale dell'Industria, 2
 Tel. +39 0464 30 30 30 - Fax +39 0464 30 30 31
 info@metalsistem.com - www.metalsistem.com

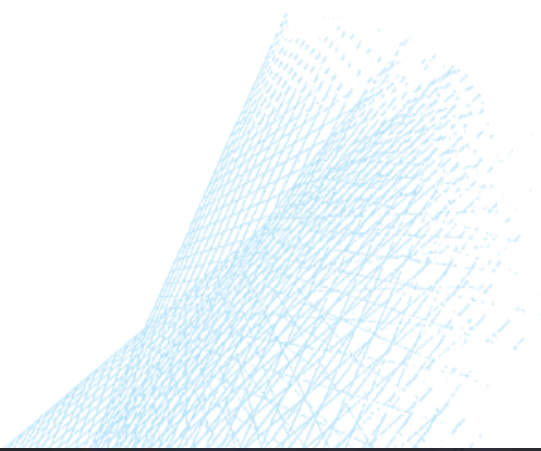

NR. EDIZIONE 01	DATA EDIZIONE 1999	NR. REVISIONE 03	DATA REVISIONE 10/2002	DATA STAMPA 5/2004
--------------------	-----------------------	---------------------	---------------------------	-----------------------