

EPT20-20RA/EPT20-20RAS  
EPT20-20RAE

# Electric Pallet Truck

## Operation Manual

**⚠ WARNING** Read and observe all warnings on this unit before operating it

**⚠ WARNING DO NOT** operate this equipment unless all factory installed guards and shields are properly secured in place

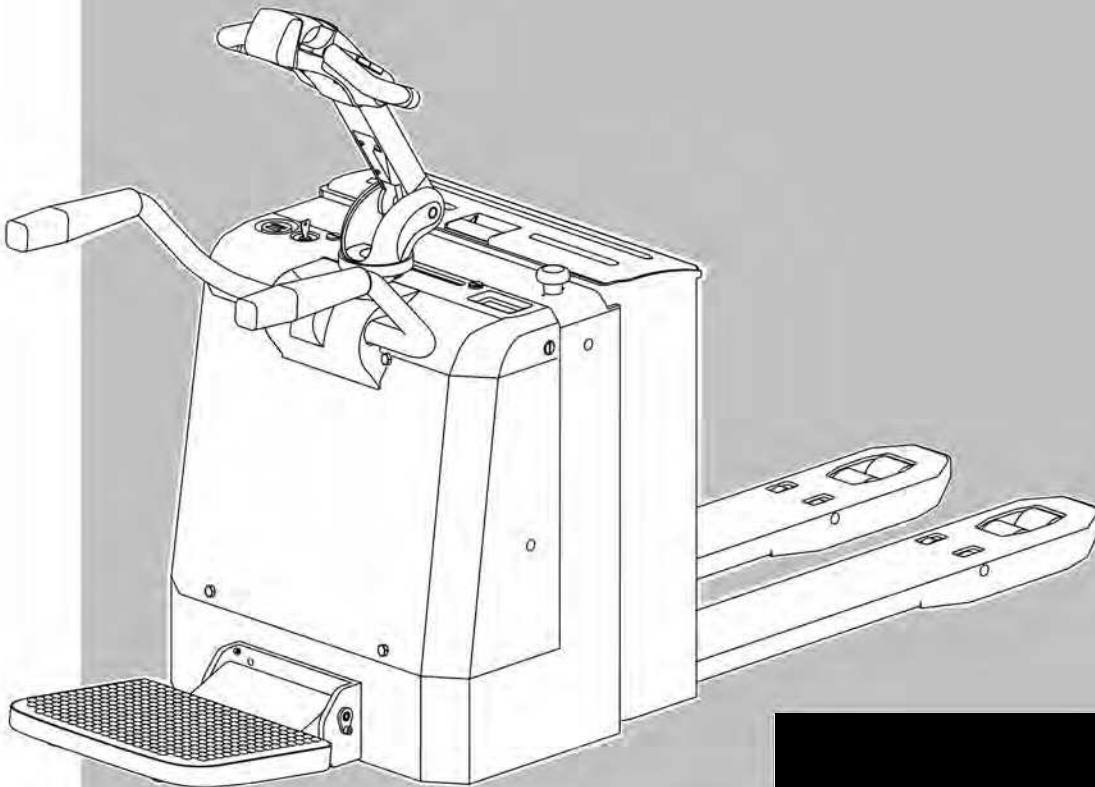

CE  
CE CERTIFICATE

# SILVERSTONE

Gjuterigatan 10, 34131 Ljungby, Sweden  
Tel +46 372-694 30, Fax +46 372-136 71  
info@silverstone.se, www.silverstone.se

---

---

## Foreword

Thanks for your purchasing our pallet truck.

This manual is about how to use, operation and maintenance EPT20-20RA/  
EPT20-20RAS/EPT20-20RAE. Please operator and whom in charge of the truck must  
read the manual carefully before operate the truck.

We have the right to improve the truck, maybe there are some difference between  
your product and the description in this manual.

If you have any questions please keep in touch with the sales department or let  
the dealer know.

## **WARNING!**

### **TO PREVENT SETIOUS RISK OF INJURY TO YOUORSELF AND OTHERS OBSERVE THE FOLLOWING SAFETY INSTRUCTIONS.**

These truck may become hazardous if adequate maintenance is neglected. Therefore, adequate maintenance facilities, trained personnel and procedures should be provided.

Maintenance and inspection shall be performed in conformance with the following practices:

1. A scheduled planned maintenance,lubrication and inspection system should be followed.
2. Only qualified and authorized personnel shall be permitted to maintain, repair, adjust, and inspect truck.
3. Before leaving the truck:
  - Do not park the truck on an incline.
  - Fully lower the load forks.
  - Set the key switch to the "OFF" position and remove the key.
4. Before starting to operate truck:
  - Be in operating position
  - Place directional control in neutral
  - Before operating truck, check functions of lift systems, directional control,speed control,steering, warning devices and brakes.
5. Avoid fire hazards and have fire protection equipment present. Do not use open flame to check lever, or for leakage of electrolyte and fluids or oil. Do not use open pans of fuel or flammable cleaning fluids for cleaning parts.
6. Brakes,steering mechanisms, control mechanisms,guards and safety devices shall be inspected regularly and maintained in legible condition.
7. Capacity, operation and maintenance instruction plates or decals shall be maintained in legible condition.
8. All parts of lift mechanisms shall be inspected to maintain them in safe operating condition.
9. All hydraulic systems shall be regularly inspected and maintained in conformance

with good practice. Cylinders, valves and other similar parts shall be checked to assure that "drift" has not developed to the extent that it would create a hazard.

10. Truck shall be kept in a clean condition to minimize fire hazards facilitate detection of loose or detective parts.

11. Modifications and additions which affect capacity and safe truck operation shall not be performed by the customer or user without manufacturers prior written approval. Capacity, operation and maintenance plates or decals shall be changed accordingly.

# Catalog

## Correct use and application

<b>1. Truck Description</b> .....	3
1.1Application.....	3
1.2 Assemblies.....	4
1.2.1Control Handle.....	5
1.2.2Key switch.....	5
1.2.3Battery discharge indicator.....	6
1.2.4Emergency brake switch.....	6
1.3 Identification points and data plates.....	7
1.3.1Truck data plate.....	8
1.4.Standard Version Specifications.....	9
1.4.1Performance data for standard trucks.....	9
1.4.2Dimensions.....	10
<b>2.Transport and Commissioning</b> .....	14
2.1Transport.....	14
2.2Using the Truck for the First Time.....	14
2.3During brake-in.....	15
<b>3.Operation</b> .....	16
3.1Safety Regulations for the Operation of pallet Trucks.....	16
3.2 Operate and run the truck.....	17
3.2.1 Preparing.....	17
3.2.2 Travel.....	17
3.2.3Lifting, transporting and depositing loads.....	20
3.2.4Parking the truck securely.....	21
<b>4.Battery Maintenance &amp; Charging</b> .....	22
4.1 Safety regulations for handling acid batteries.....	22
4.2 Battery type & dimension.....	22
4.3Charging the battery.....	23
4.3.1Exposing the battery.....	23
4.3.2 Charging.....	23
4.4Battery removal and installation.....	24
4.5Battery maintenance.....	24
4.6Battery Disposal.....	25
<b>5.pallet Truck Maintenance</b> .....	26
5.1Operational safety and environmental protection.....	26
5.2Maintenance Safety Regulations.....	26
5.3Servicing and inspection.....	28

5.3.1 Maintenance Checklist.....	29
5.3.2 Lubrication Schedule.....	31
5.3.3 Maintenance Instructions.....	32
5.4 Decommissioning the industrial truck.....	35
5.4.1 Prior to decommissioning.....	35
5.4.2 Restoring the truck to operation after decommissioning.....	35
5.5 Safety checks to be performed at regular intervals and following any unusual incidents.....	36
5.6 Final de-commissioning, disposal.....	36
<b>6. Troubleshooting.....</b>	<b>37</b>

## **Correct use and application**

The "Guidelines for the Correct Use and Application of Industrial Trucks" (VDMA) are supplied with the truck. The guidelines form part of these operating instructions and must be observed. National regulations apply in full.

The truck described in the present operator manual is an industrial truck designed for lifting and transporting load units.

It must be used, operated and serviced in accordance with the present instructions. Any other type of use is beyond the scope of application and can result in damage to personnel, the truck or property. In particular, avoid overloading the truck with loads which are too heavy or placed on one side. The data plate attached to the truck or the load diagram are binding for the maximum load capacity. The industrial truck must not be used in fire or explosion endangered areas, or areas threatened by corrosion or excessive dust.

### **Proprietor responsibilities**

For the purposes of the present operator manual the "proprietor" is defined as any natural or legal person who either uses the industrial truck himself, or on whose behalf it is used. In special cases (e.g. leasing or renting) the proprietor is considered the person who, in accordance with existing contractual agreements between the owner and user of the industrial truck, is charged with operational duties.

The proprietor must ensure that the truck is used only for the purpose it is intended for and that danger to life and limb of the user and third parties are excluded.

Furthermore, accident prevention regulations, safety regulations and operating, servicing and repair guidelines must be followed. The proprietor must ensure that all truck users have read and understood this operator manual.

Failure to comply with the operator manual shall invalidate the warranty. The same applies if improper work is carried out on the truck by the customer or third parties without the permission of the manufacturer's customer service department.

### **Attaching accessories**

The mounting or installation of additional equipment which affects or supplements the performance of the industrial truck requires the written permission of the manufacturer. In some cases, local authority approval shall be required.

Approval of the local authorities however does not constitute the manufacturer's Approval.

## 1. Truck Description

### 1.1 Application

The truck is a tiller operated electric pallet truck with a folding operator platform and side arms.

The truck is designed for lifting and transporting goods on a level surface. The truck can pick up, outside the load wheel area, open bottom or diagonal board pallets as well as roll cages. The capacity of the truck is shown on the data plate or the data capacity plate Qmax.

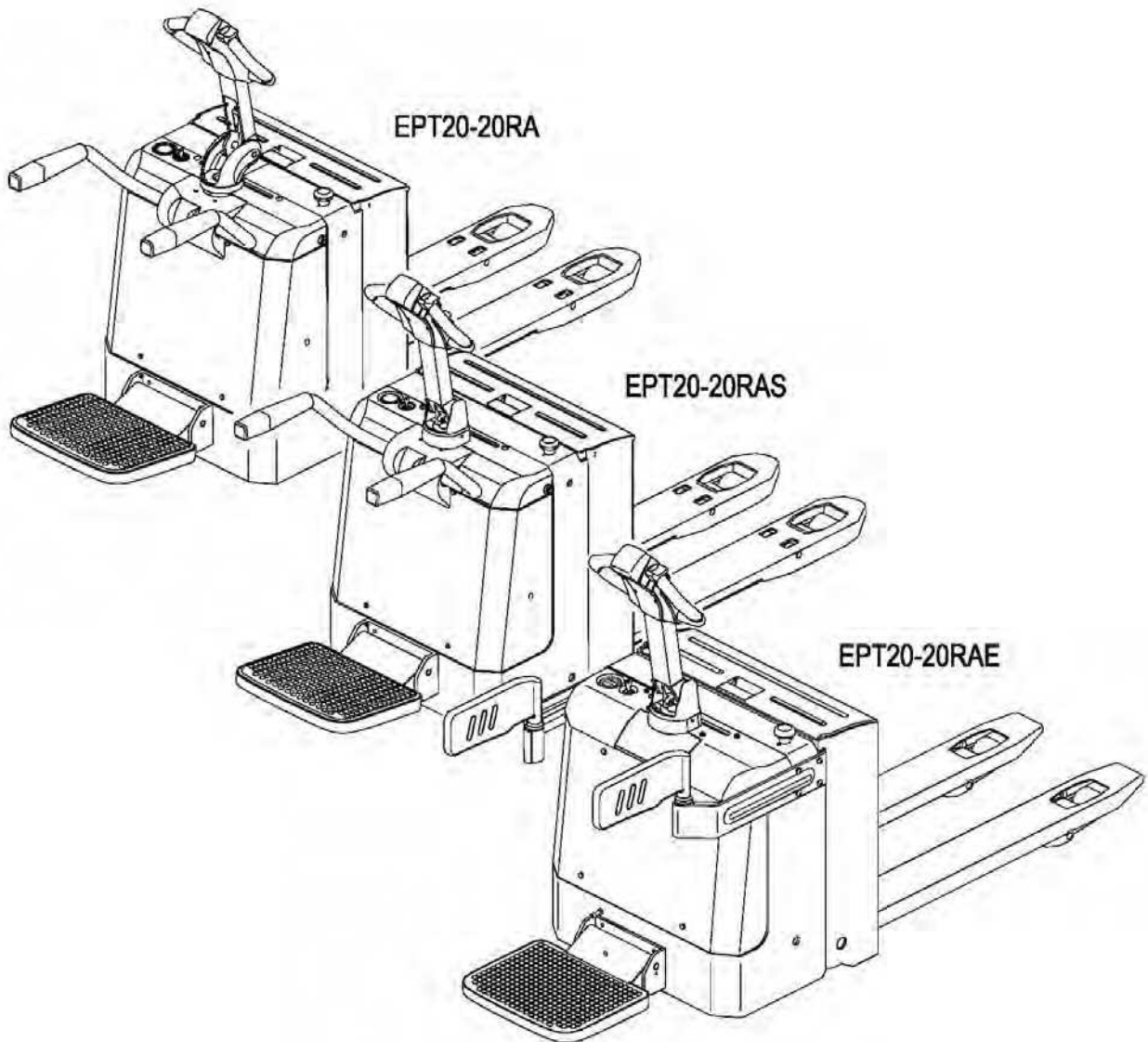



## 1.2 Assemblies

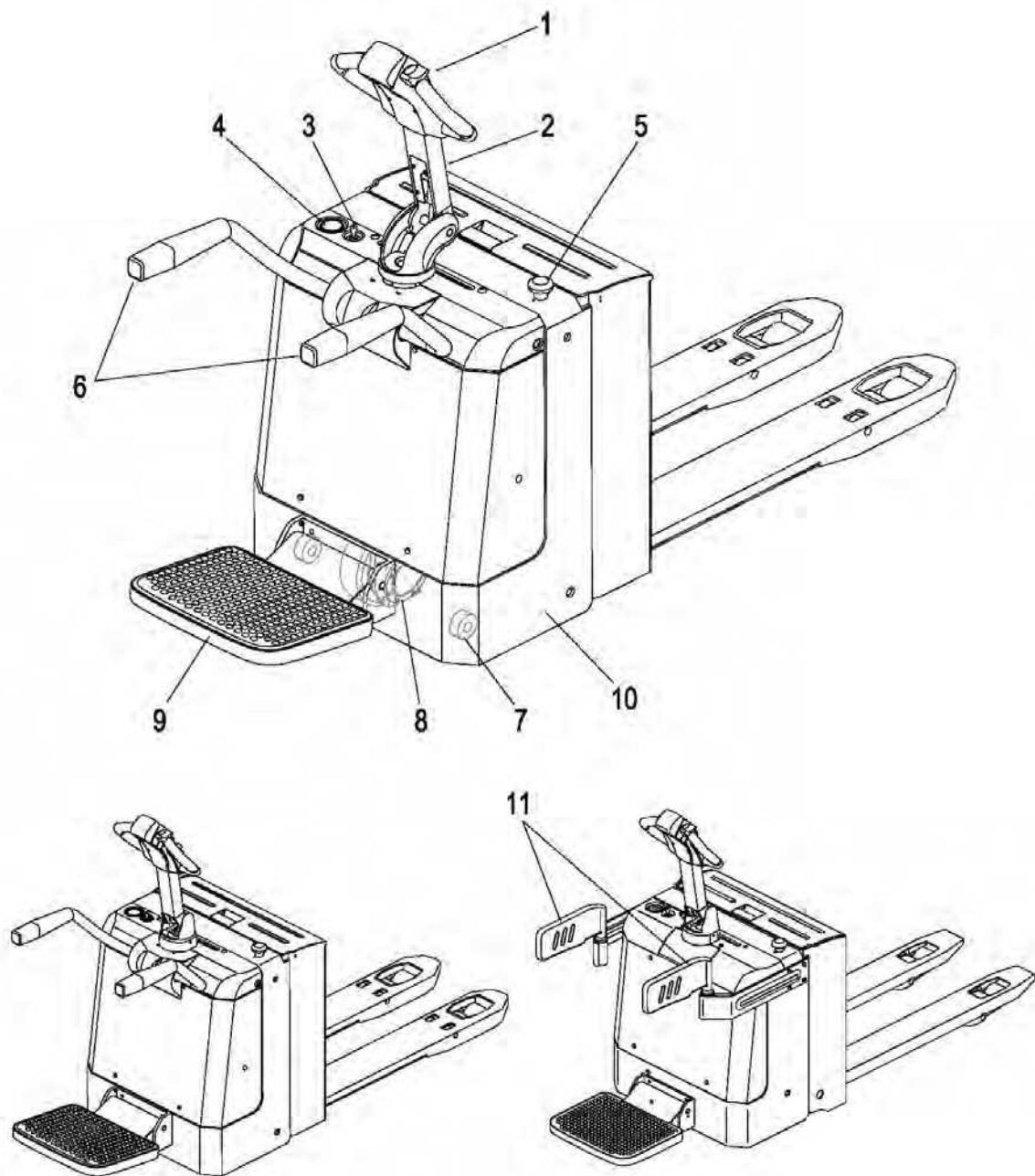

Item	Description	Item	Description
1	Travel switch	7	Caster wheel
2	Tiller	8	Drive wheel
3	Key switch	9	Folding operator platform
4	Battery discharge indicator	10	Ram protection
5	Emergency brake switch	11	Side arm
6	Side arm		

### 1.2.1 Control Handle

12	"Lower" button	Lowers load forks.
13	"Lift" button	Raises load forks.
14	Travel switch	Controls the driving speed and direction
15	Warning signal button	Triggers a warning signal.
16	Collision safety switch	Safety function which, when activated, forces the truck to reverse until the switch restored to neutral.

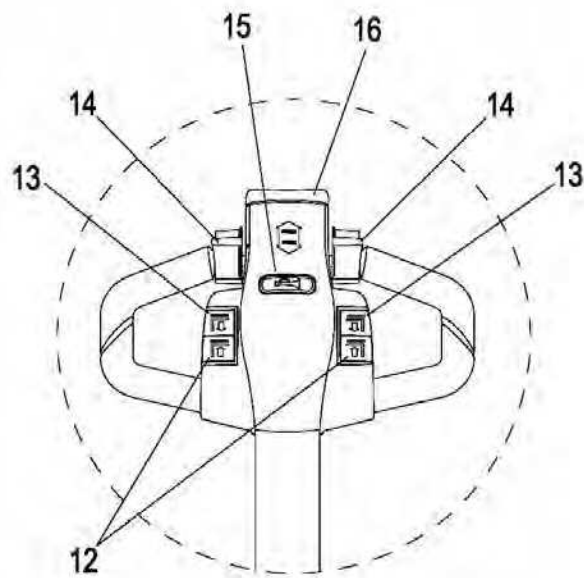

### 1.2.2 Key switch

Switches control current on and off.

Removing the key prevents the truck from being switched on by unauthorised personnel.

### 1.2.3 Battery discharge indicator

The LEDs (1) represent battery residual capacity, The LCD (2) displays the operating hours

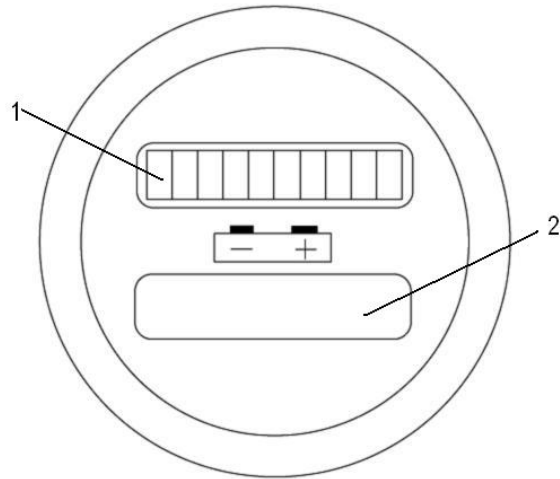

#### Battery Discharge Indicator(1)

When the truck has been released via the key switch, the battery charge status is displayed.

The colours of the LEDs (1) represent the following conditions:

LED colour		value
Green	Standard battery residual capacity	70-100%
Orange	Standard battery residual capacity	50-60%
Flashing Red	Standard battery residual capacity	0-20%

Battery Discharge for 70%, A flashing red show on storage battery charge warning.

Battery Discharge for 80%, Two flashing reds show on battery charge used up warning, Lifting is now inhibited. The battery must be charged.

#### Operating hours display

Display range between 0.0 and 99,999.0 hours. Travel and lifting are logged. This is a backlit display.

#### Power up test

On power up the display shows:

- the operating hours
- the charge status

### 1.2.4 Emergency brake switch

The supply current is interrupted, all electrical functions are deactivated and the truck is automatically braked.

### 1.3 Identification points and data plates

Item	Description
1	Logo decal
2	Decal hook-up caution
3	Hook decal
4	Plate data
5	Decal operation warning
6	AC power decal

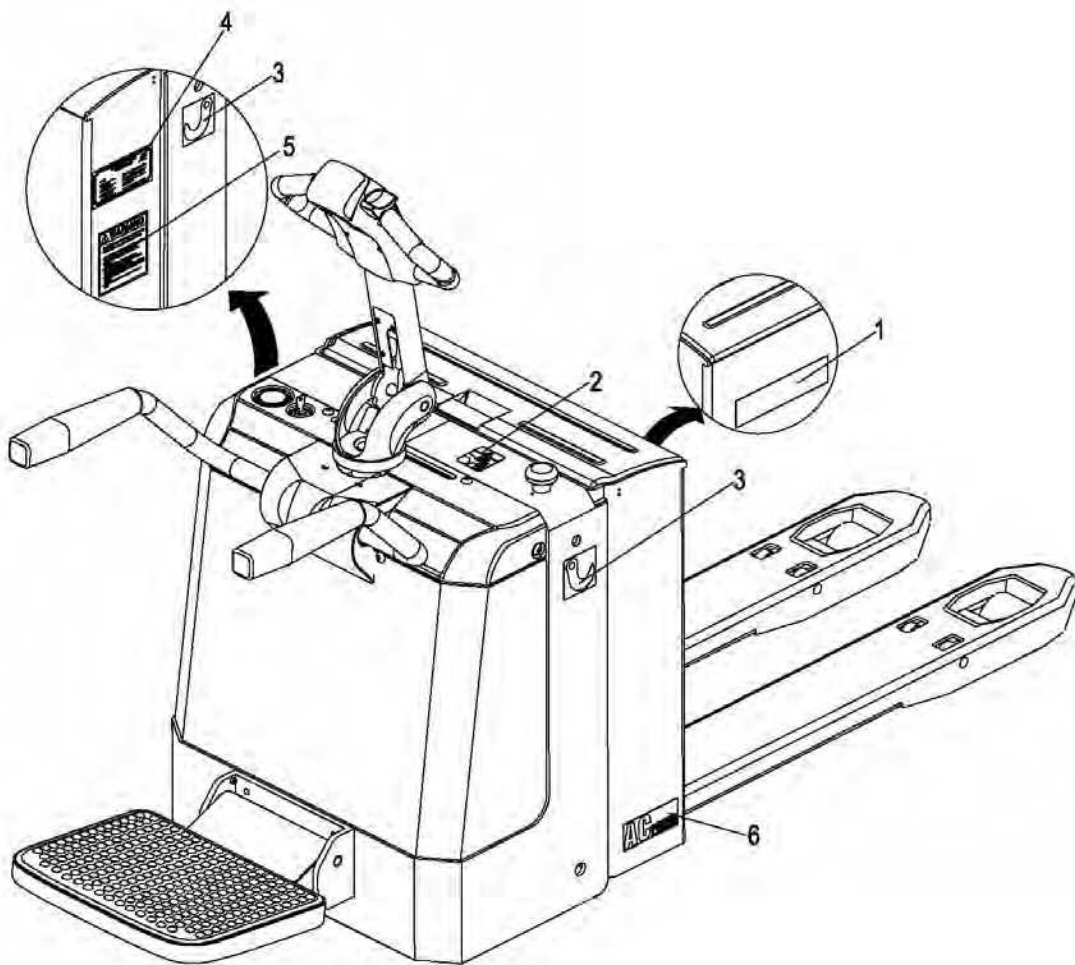

### 1.3.1 Truck data plate

Item	Description	Item	Description
1	Manufacturer	6	Fork length (mm)
2	Model name	7	(Recommendation) Battery capacity (Ah)
3	Type	8	Net weight w.o. battery (kg)
4	Rated capacity (kg)	9	Serial no.
5	Fork width(mm)		

For queries regarding the truck or ordering spare parts always quote the truck serial number (9).

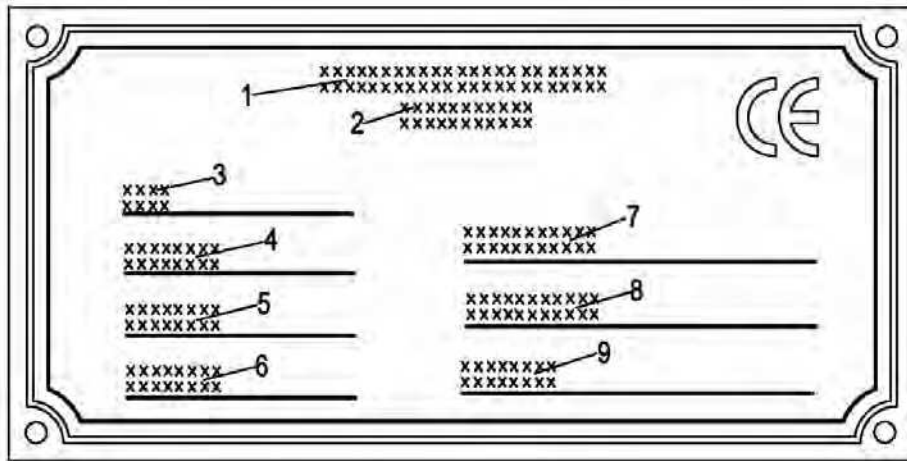

### MODEL NUMBER EXAMPLE

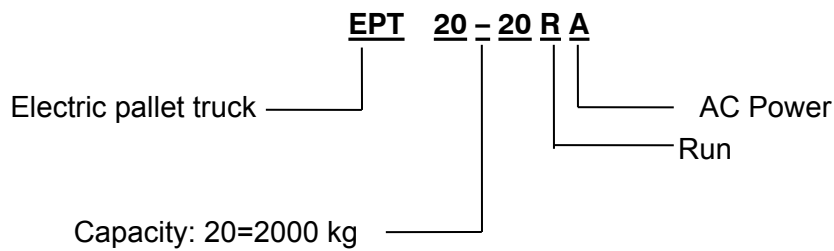

## 1.4. Standard Version Specifications

Technical specification details in accordance with JB/T3773.1-84. Technical modifications and additions reserved.

### 1.4.1 Performance data for standard trucks

Item	Description		EPT20-20RA	EPT20-20RAS	EPT20-20RAE	Unit
Q	Load capacity		2000	2000	2000	kg
C	Load center		600	600	600	mm
	Travel speed	laden	7.5	7.5	5.5	km/h
		unladen	8.5	8.5	6.0	km/h
	Lifting speed	laden	0.056	0.056	0.051	m/s
		unladen	0.060	0.060	0.060	m/s
	Lowering speed	laden	0.057	0.027	0.032	m/s
		unladen	0.057	0.027	0.039	m/s
	Maximum grade ability S <sub>2</sub> 5 min.	laden	8	8	6	%
		unladen	16	16	8	%
	Service brake		Electromagnetic	Electromagnetic	Electromagnetic	
	Service weight	Incl. battery	670	670	545	kg
	Axle loading, laden	operator/load side	1066/ 1604	1066/ 1604	—	kg
	Axle loading, unladen	operator/load side	546/ 124	546/ 124	—	kg
	Motor rating power	Drive	1.5	1.5	1.1	Kw
		Lift	2.2	2.2	0.8	Kw
	Tyre type		PU/PU	PU/PU	PU/PU	
	Tyre size, operator side		Φ230×75	Φ230×75	Φ230×75	
	Tyre size, load side		2× Φ85×70	Φ85×70	Φ80×60	
	Balance wheels (dimensions)		Φ130×60	Φ130×60	Φ85×48	
	Battery	Type	Industry battery	Industry battery	Industry battery	
		voltage/rated capacity	24/210	24/210	2×12/150	V/Ah
		weight	190	190	2×54	kg
	Sound level at operator's ear		74	74	70	dB(A)

### 1.4.2Dimensions

Item	Description		EPT20-20RA		EPT20-20RAS		EPT20-20RAE	Unit
X	Load distance (Raised/ Lowered)		916/ 982	937/ 1003	978		946	mm
Y	Wheelbase		1420	1440	1420		1374	mm
h3	Lift height		125		125		120	mm
b11	Tread	load side	370/ 515		370/ 515		390	mm
h13	Fork height	lowered	85		85		85	mm
h14	Height of tiller arm in operating position	min	1150		1150		1150	mm
		max	1470		1470		1470	mm
l1	Overall length		1860	1930	1860		1828	mm
l2	Length to face of forks		710		710		586	mm
b1	Overall width		730		730		734	mm
s	Fork dimensions	Thickness	55	55	55	55	55	mm
e		Width	170	170	170	170	150	mm
l		Length	1150	1220	1150	1220	1150	mm
b5	Fork spread		540/ 685		540/ 685		540/ 685	mm
m2	Ground clearance		35		50		50	mm
Wa	Outer turning radius		1700	1725	1700	1725	1553	mm
Ast	Aisle width	1000×1200 pallet crossways	2034		1984		1807	mm
		800×1200 pallet lengthways	2084		2184		2007	mm

EPT20-20RA

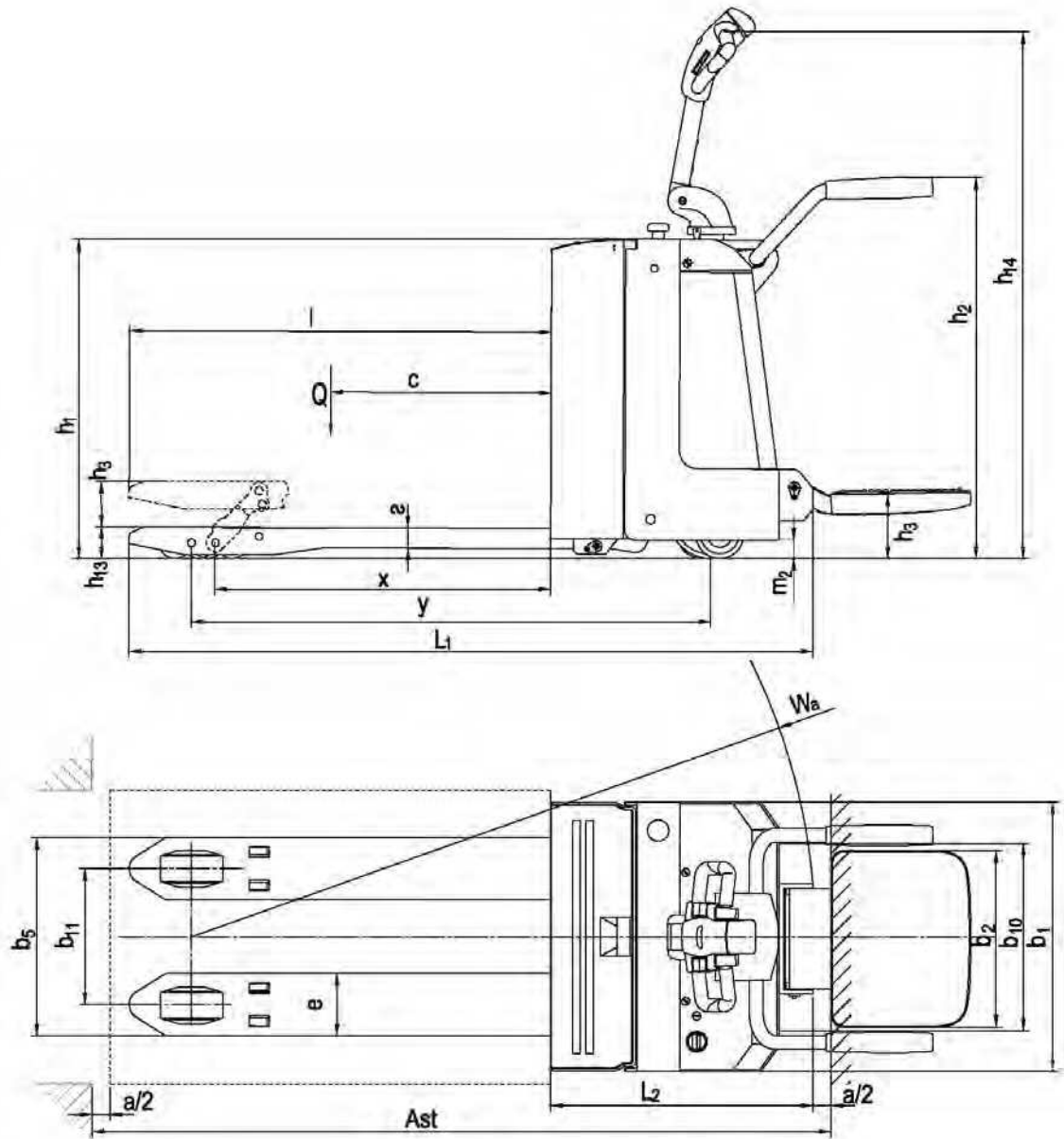



EPT20-20RAS

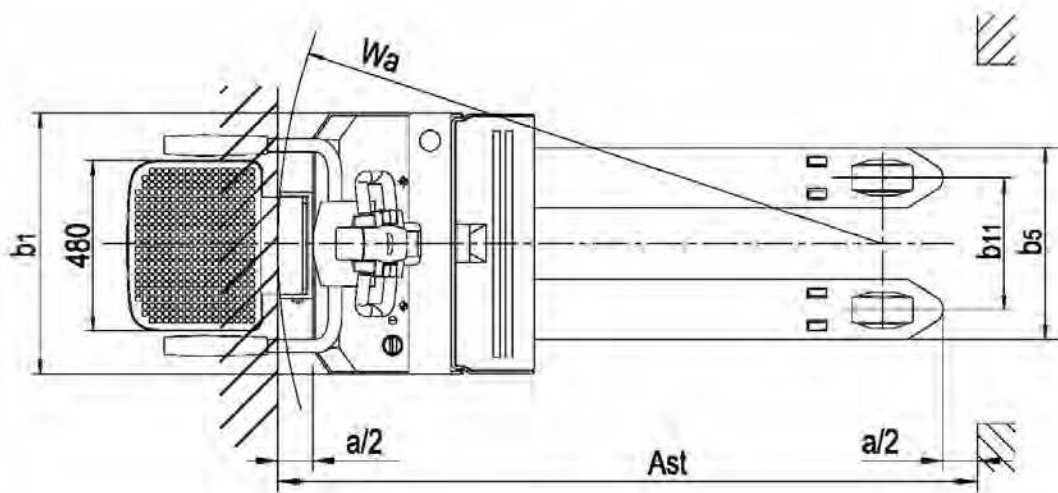
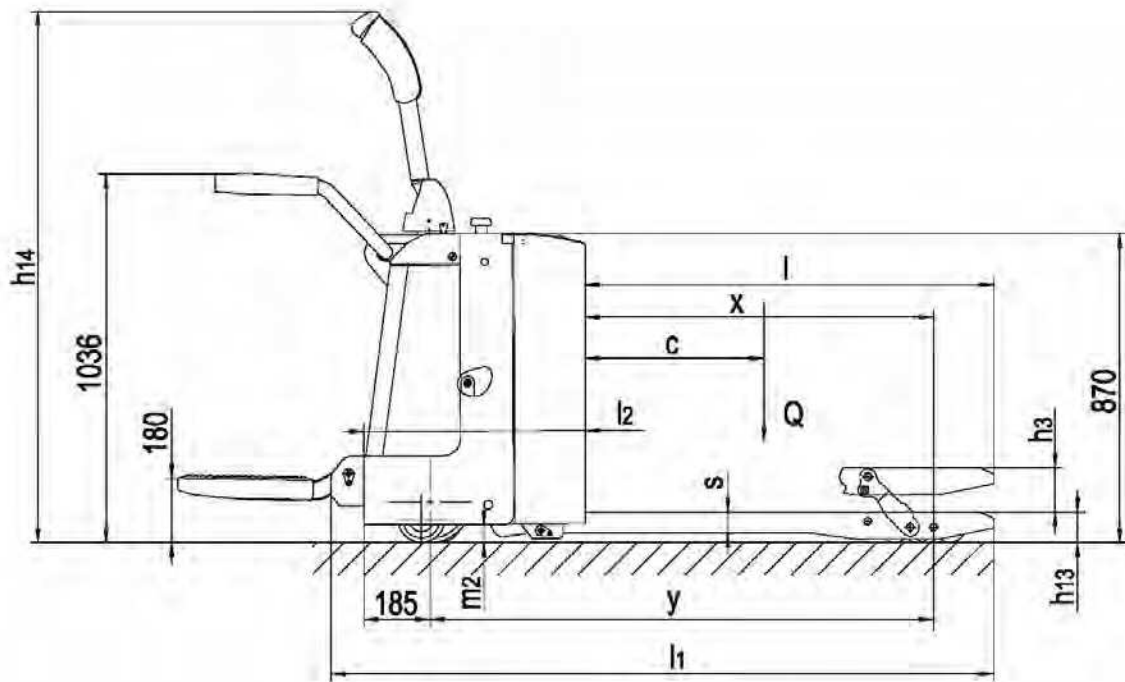

EPT20-20RAE

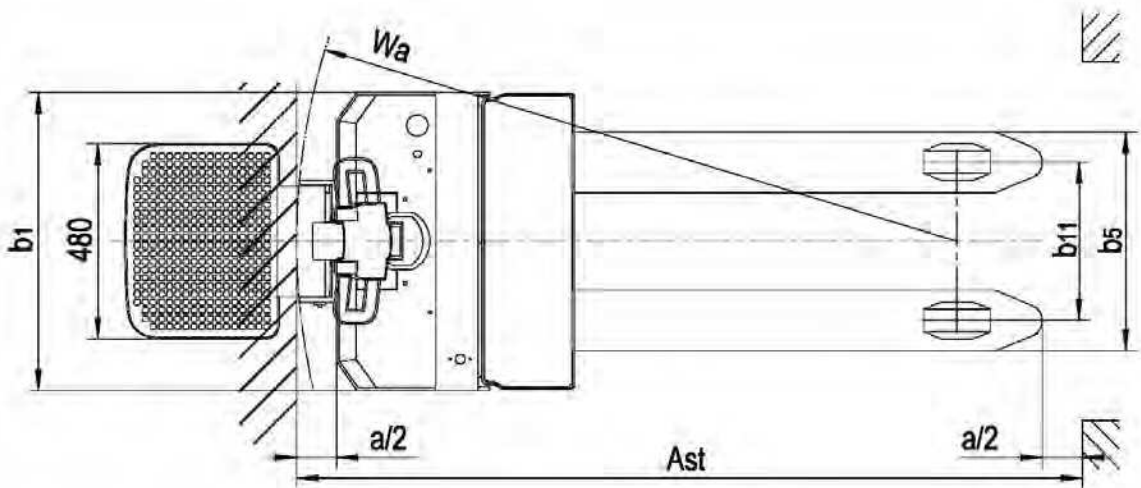
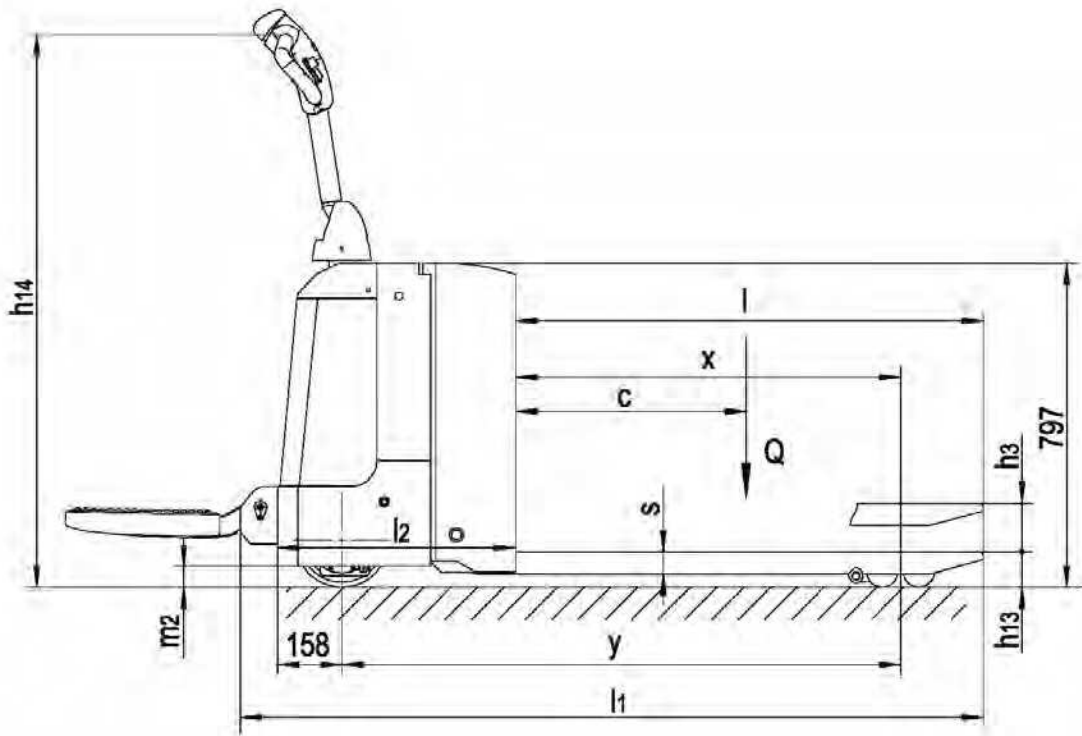

## 2. Transport and Commissioning

### 2.1 Transport

#### Lifting the truck by crane

There are two way to pack the truck: one is use a stock, the other is use a box. The way to pick up depend on transport.

1. Only use crane handling equipment gear with sufficient capacity.

2. Loading weight > net weight of truck (+ battery weight for electric trucks). Loading weight not only net weight of truck but also the stock or the box.

3. Stock (box) should be big enough and strong enough to bear hole truck.

– Park the truck securely.(see 3.2.4 Parking the truck securely on page 21).

– Make sure forks are positioned properly for the pallet. Move forward slowly to insert forks into the pallet as far as possible and then stop the truck.

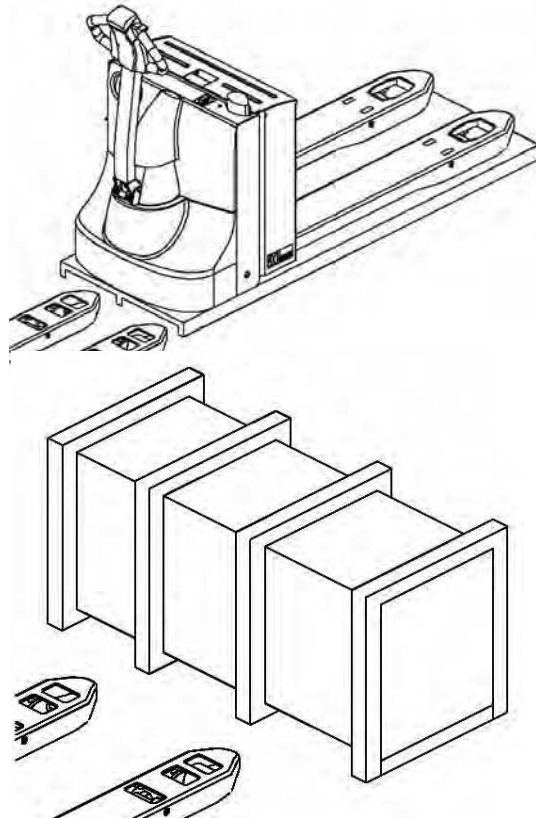

#### Warning!

- To avoid break the fork be hurt when you move the truck to stock.
- In order to keep the truck out of be scraped, please move the truck void in void and flat place.
- when you lowering the stock advert status of the place to avoid collapse.

### 2.2 Using the Truck for the First Time

Only operate the truck with battery current. Rectified AC current will damage the electronic components. Cable connections to the battery (tow leads) must be less than 6 m .

Preparing the truck for operation after delivery or transport

Procedure

- Check the equipment is complete.
- Check the hydraulic oil level.
- Install the battery if necessary (where required), (see "4.4 Battery removal and installation" on page 24) do not damage battery cable.
- Charge the battery, (see "4.3 Charging the battery" on page 23).

When the truck is parked the surface of the tyres will flatten. The flattening will disappear after a short period of operation.

### **2.3 During brake-in**

We recommended operating the machine under light load conditions for the first stage of operation to get the most from it. Especially the requirements given below should be observed while the machine is in a stage of 100 hours of operation.

1. Must prevent the new battery from over discharging when early used. Please charging when remain power less than 20%.
2. Perform specified preventive maintenance services carefully and c.ompletely.
3. Avoid sudden stop, starts or turns.
4. Oil changes and lubrication are recommended to do earlier than specified.
5. Limited load is 70~80% of the rated load.

### 3.Operation

#### 3.1 Safety Regulations for the Operation of pallet Trucks

**Driver authorisation:** The pallet truck may only be used by suitably trained personnel, who have demonstrated to the proprietor or his representative that they can drive and handle loads and have been authorised to operate the truck by the proprietor or his representative.

**Driver's rights, obligations and responsibilities:** The driver must be informed of his duties and responsibilities and be instructed in the operation of the truck and shall be familiar with the operator manual. The driver shall be afforded all due rights. Safety shoes must be worn with pedestrian operated trucks.

**Unauthorised Use of Truck:** The driver is responsible for the truck during the time it is in use. He shall prevent unauthorised persons from driving or operating the truck. It is forbidden to carry passengers or lift personnel.

**Damage and Faults:** The supervisor must be immediately informed of any damage or faults to the pallet truck. Trucks not safe for operation (e.g. wheel or brake problems) must not be used until they have been rectified.

**Repairs:** The driver must not carry out any repairs or alterations to the pallet truck without the necessary training and authorisation to do so. The driver must never disable or adjust safety mechanisms or switches.

**Hazardous area:** A hazardous area is defined as the area in which a person is at risk due to truck movement, lifting operations, the load handler (e.g. forks or attachments) or the load itself. This also includes areas which can be reached by falling loads or overhanging operating equipment.

Unauthorised persons must be kept away from the hazardous area. Where there is danger to personnel, a warning must be sounded with sufficient notice. If unauthorised personnel are still within the hazardous area the truck shall be brought to a halt immediately.

**Safety Devices and Warning Signs:** Safety devices, warning signs and warning instructions shall be strictly observed.

## **3.2 Operate and run the truck**

### **3.2.1 Preparing**

Before the truck can be commissioned, operated or a load unit lifted, the driver must ensure that there is nobody within the hazardous area.

#### **Checks and operations to be performed before starting daily work**

- Visually inspect the entire truck (in particular wheels and load handler) for obvious damage.
- Visually inspect the battery attachment and cable connections.

#### **Switching on the truck**

- Make sure the switch is depressed.
- Insert the key in the key switch and turn it to the right as far as it will go ( position “ON”)
- Test the warning button .

The truck is now operational.

The battery discharge indicator indicates the existing battery charge status.

- Test the braking operation of the tiller.

### **3.2.2 Travel**

We distinguish between two travel modes:

Truck with a folding operator platform and moving tiller.

Do not reach between the operator platform and the truck panel when you fold up the platform.

- Pedestrian mode:

Push the side arms in, fold up the operator platform (1). The truck can only be operated at the reduced travel speed.

- Rider mode:

Push the side arms out, fold down the operator platform (1). The truck can be operated at maximum speed.

**General:**

- Set the tiller (5) to the travel zone (F).
- Turn the controller (4) to the required direction (fwd. or rev.).

If the side arms are not folded out, the truck can only be operated at reduced speed. Do not drive the truck unless the panels are closed and properly locked. When travelling through swing doors etc. make sure that the doors do not activate the collision safety button (3).

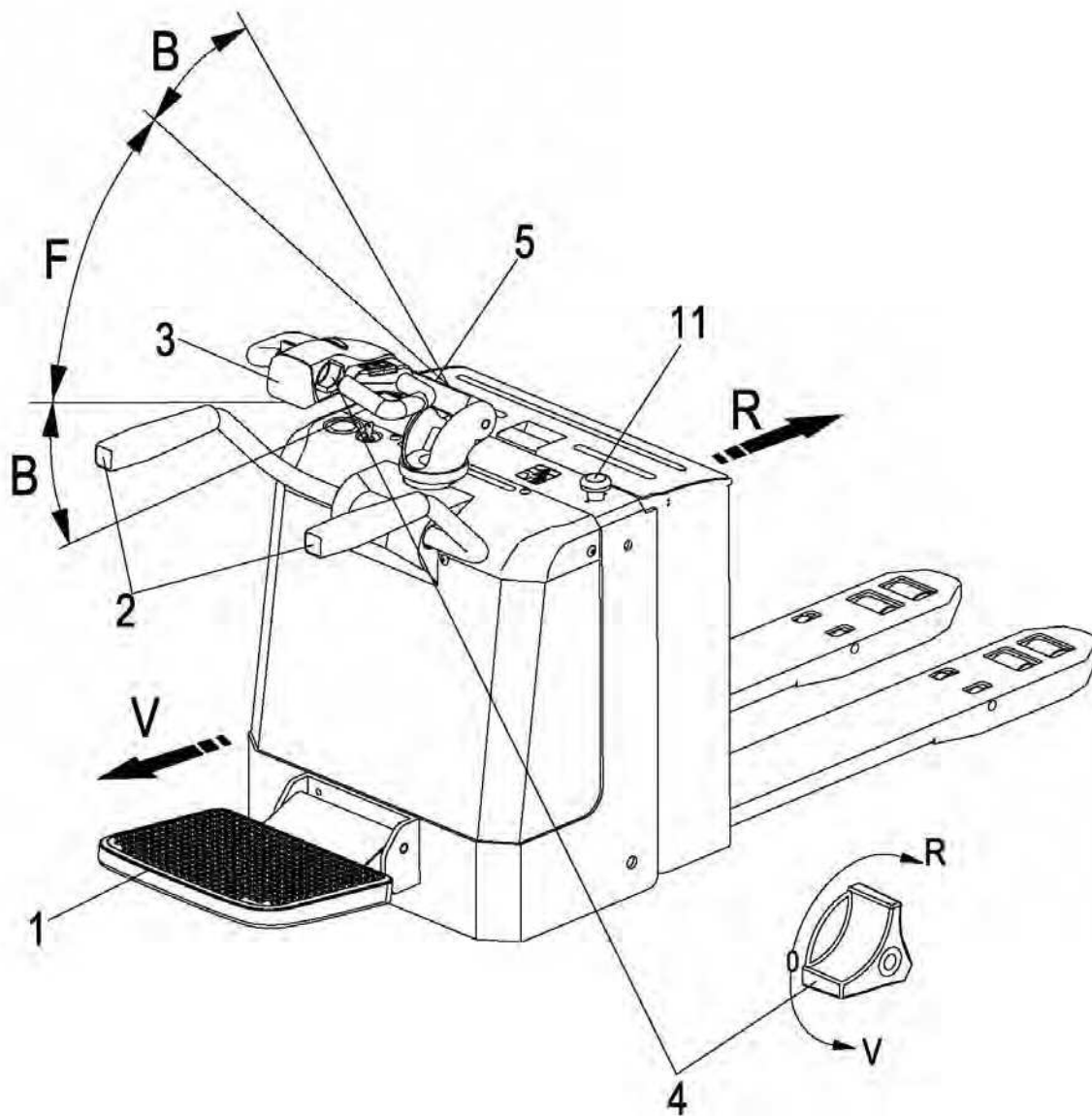

## **Steering**

In narrow bends the driver extends beyond the geometry of the truck.

- Move the tiller (5) to the left or right.

## **Braking**

The brake pattern of the truck depends largely on the ground conditions. The driver must take this into account when operating the truck.

The truck can brake in three different ways:

- by plugging
- by using the operating brake
- with the emergency brake switch (Emergency Disconnect)

### **Plugging:**

- When travelling, set the controller (8) to the opposite direction.

The truck brakes regeneratively until it starts to move in the opposite direction.

The rate of braking depends on the position of the controller.

### **Braking with the service brake:**

- Set the tiller (5) to one of the brake zones (B).

The drive motor brakes regeneratively ( motor brake ) . Only when this brake fails to achieve the necessary brake force is the mechanical brake ( magnetic brake) applied.

When the truck is idle the magnetic brake (magnetic brake) applies.

When the tiller is released it reverts to the upper braking zone (B).

### **Braking with the Emergency brake switch:**

- Pull Emergency brake switch (11) up.

The circuit is interrupted , all electrical functions are cut out and the truck automatically brakes (magnetic brake).

### **Switching Speed Mode:**

- Put side arm (2) down.

Controller start the mode of half speed.

**ES20-20RAE(E Series) does not have the function.**



### 3.2.3 Lifting, transporting and depositing loads

#### Unsecured and incorrectly positioned loads can cause accidents

- Instruct other people to move out of the hazardous area of the truck. Stop working with the truck if people do not leave the hazardous.

- Only carry loads that have been correctly secured and positioned. Use suitable precautions to prevent parts of the load from tipping or falling down.

- Do not transport with bad handbarrow ( as truck and stock ) .

- Never stand underneath a raised load handler.

- Do not stand on the load handler.

- Do not lift other people on the load handler.

- Insert the forks as far as possible underneath the load.

#### **Warning!**

Before lifting a load unit the driver must make sure that it has been correctly stowed and does not exceed the truck's capacity.

Do not lift long loads at an angle.

#### **Lift**

Press "Lift" button(8) until the height you need.

#### **Warning!**

Don't lift to tiptop, to avoid shorted life of oil cylinder.

#### **Lower**

Press "Lower" button (7) until the lowest position.

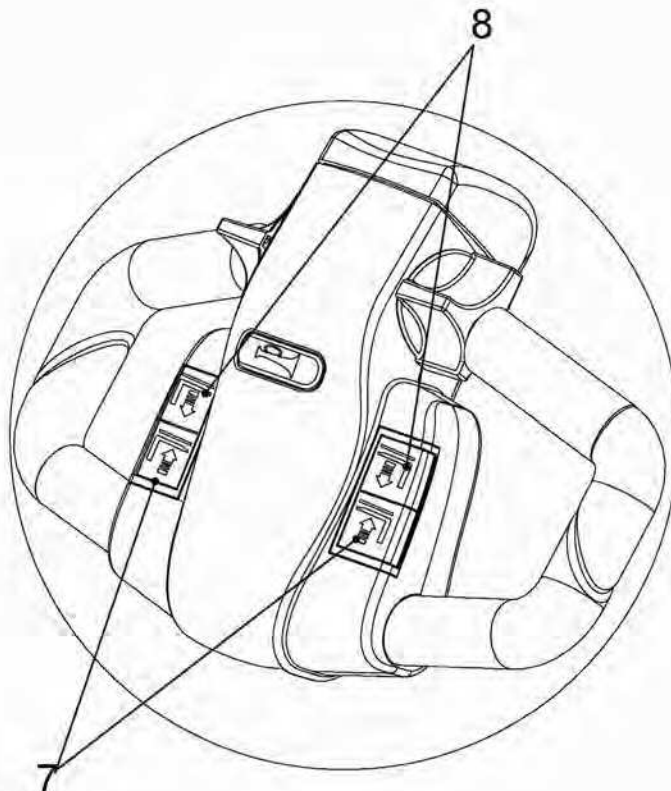

### **3.2.4 Parking the truck securely**

When you leave the truck it must be securely parked even if you only intend to leave it for a short time.

- Do not park the truck on an incline.
- Fully lower the load forks.
- Set the key switch to the "OFF" position and remove the key.
- Drawing back the emergency brake switch .
- Fold in the folding side arm

Do not reach between the operator platform and the truck panel when you fold up the folding platform.

## 4. Battery Maintenance & Charging

### 4.1 Safety regulations for handling acid batteries

Park the truck securely before carrying out any work on the batteries.

#### Maintenance personnel :

Batteries may only be charged, serviced or replaced by trained personnel .The present operator manual and the manufacturer 's instructions concerning batteries and charging stations must be observed when carrying out the work.

#### Fire protection :

- Smoking and naked flames must be avoided when working with batteries.
- Wherever a truck is parked for charging there shall be no inflammable material or operating fluids capable of creating sparks within 2 metres around the truck.
- The area must be well ventilated.
- Fire protection equipment must be provided.



#### Protection against electric shock:

- Battery has high voltage and energy.
- Do not bring short circuit.
- Do not approach tools to the two poles of the battery, which can cause the sparkle.

### 4.2 Battery type & dimension

Battery type & dimension as follow :

Truck type	Battery type	voltage/ rated capacity	Battery height (mm)	Battery length (mm)	Battery width (mm)
ES20-20RA ES20-20RAS	Industry battery	24/210	540	650	200
ES20-20RAE	Industry battery	2×12/150	241	483	170

When replacing or installing batteries, ensure that the battery is correctly secured in the battery compartment of the truck.

## 4.3 Charging the battery

### 4.3.1 Exposing the battery

Park the truck securely .

– Drawing back the emergency brake switch (3).

Lift up the battery panel (1) using the grip mould (2) and fold it back.

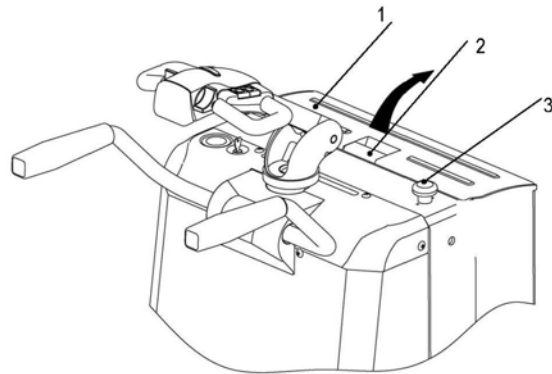

### 4.3.2 Charging

#### Safety regulations for Charging the battery

– To charge the battery, the truck must be parked in a closed and properly ventilated room. When charging, the tops of the battery cells must be exposed to provide sufficient ventilation.

– Do not place any metal objects on the battery.

– Before charging, check all cables and plug connections for visible signs of damage.

– Forbid add water to battery directly.

– Before start and finish charging to make sure power is turn OFF.

– It is essential to follow the safety regulations of the battery and charging station manufacturers.

#### Warning!

Before closing the battery cover make sure that the battery lead cannot be damaged.

#### Charging step

– Check whether the condition is according with "Safety regulations for Charging the battery".

– Park the truck securely(See 3.2.4 Parking the truck securely Page21 ).

– Remove the battery plug (4).

– Connect the battery plug (4) with the charging lead of the stationary charger (5) and turn on the charger.

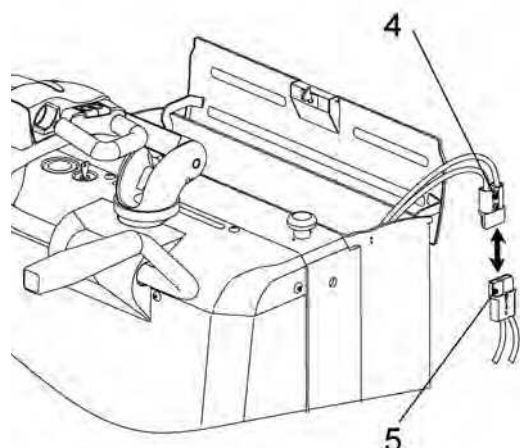

#### 4.4 Battery removal and installation

When transporting batteries using a crane ensure that the crane is of adequate capacity ( the battery weight is indicated on the battery data plate on the battery container) . The crane lifting gear must exert a vertical pull. The hooks of the lifting gear must never fall into the battery cells.

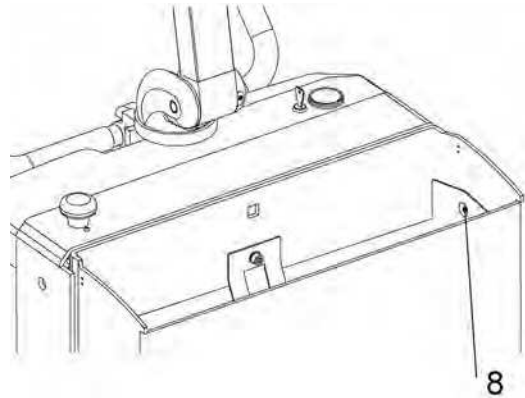

- Expose the battery (see Section 3).
- Remove the battery connector (3).
- Strap the crane lifting gear to the eyes (8).
- Drawing back the emergency brake switch.

Installation is the reverse order . When reinstalling the battery , note the proper installation position and make sure the battery is connected correctly.

- After installing the battery again , check all cables and plug connections for visible signs of damage.

Close the battery panel carefully and slowly.  
Do not reach between the battery panel and the chassis.

#### 4.5 Battery maintenance

##### **Do not overuse battery:**

- If you use up the energy of battery till the pallet immovability, you will shorten its working hours.
- Shower for battery appears need for charge, please charge it quickly.

##### **Inspection for electrolyte:**

- Do not using pallet which is absent electrolyte.
- Inspection for electrolyte level every week.
- When electrolyte level is low, you must add distilled water to the level appointed.

##### **Battery maintenance:**

The battery cell covers must be kept dry and clean. The terminals and cable shoes must be clean, secure and have a light coating of dielectric grease. Batteries with non insulated terminals must be covered with a non slip insulation mat.

**Warning!**

1. Do not use dry cloth or fibre cloth to clean the battery, avoiding static to bring the explosion.
2. Unfixing battery plug.
3. Cleaning with wet cloth.
4. Wearing glasses for protecting eyes rubber overshoes and rubber glove.

**4.6 Battery Disposal**

Batteries may only be disposed of in accordance with national environmental protection regulations or disposal laws. The manufacturer's disposal instructions must be followed.

Batteries contain an acid solution which is poisonous and corrosive . Therefore , always wear protective clothing and eye protection when carrying out work on batteries . Above all avoid any contact with battery acid.

Nevertheless, should clothing, skin or eyes come in contact with acid the affected parts should be rinsed with plenty of clean water-where the skin or eyes are affected call a doctor immediately. Immediately neutralise any spilled battery acid.

Only batteries with a sealed battery container may be used.

The weight and dimensions of the battery have considerable affect on the operational safety of the truck. Battery equipment may only be replaced with the agreement of the manufacturer.

## **5.pallet Truck Maintenance**

### **5.1Operational safety and environmental protection**

- The servicing and inspection operations contained in this chapter must be performed in accordance with the intervals indicated in the servicing checklists.
- Any modification to the pallet truck assemblies, in particular the safety mechanisms, is prohibited. The operational speeds of the truck must not be changed under any circumstances.
- Only original spare parts have been certified by our quality assurance department. To ensure safe and reliable operation of the pallet truck, use only the manufacturer's spare parts. Used parts, oils and fuels must be disposed of in accordance with the relevant environmental protection regulations. For oil changes, contact the manufacturer's specialist department.
- Upon completion of inspection and servicing, carry out the activities listed in the "Recommissioning (on page 34)" section.

### **5.2Maintenance Safety Regulations**

#### **Maintenance personnel**

Industrial trucks must only be serviced and maintained by the manufacturer's trained personnel.

The manufacturer's service department has field technicians specially trained for these tasks. We therefore recommend a maintenance contract with the manufacturer's local service centre.

#### **Lifting and jacking up**

When an industrial truck is to be lifted, the lifting gear must only be secured to the points specially provided for this purpose.

When jacking up the truck, take appropriate measures to prevent the truck from slipping or tipping over (e.g. wedges, wooden blocks).

You may only work underneath a raised load handler if it is supported by a sufficiently strong chain.

#### **Cleaning**

Do not use flammable liquids to clean the industrial truck.

Prior to cleaning, all safety measures required to prevent sparking (e.g. through short circuits) must be taken. For battery-operated trucks, the battery connector must be removed.

Only weak suction or compressed air and non-conductive antistatic brushes may be used for cleaning electric or electronic assemblies.

If the truck is to be cleaned with a water jet or a high-pressure cleaner, all electrical

and electronic components must be carefully covered beforehand as moisture can cause malfunctions.

Do not clean with pressurised water.

After cleaning the truck, carry out the activities detailed in the “Recommissioning (on page 34)” section.

### **Electrical System**

Only suitably trained personnel may operate on the truck’s electrical system.

Before working on the electrical system, take all precautionary measures to avoid – electric shocks.

For battery-operated trucks, also de-energise the truck by removing the battery connector.

### **Welding**

To avoid damaging electric or electronic components, remove these from the truck before performing welding operations.

### **Settings**

When repairing or replacing hydraulic, electric or electronic components or assemblies, always note the truck-specific settings.

### **Tyres**

The quality of tyres affects the stability and performance of the truck. When replacing factory fitted tyres only used original manufacturer’s spare parts, as otherwise the data plate specifications will not be kept.

When changing wheels and tyres, ensure that the truck does not slew (e.g. when replacing wheels always left and right simultaneously).

### **Lift chains**

Lift chains wear rapidly if not lubricated.

The intervals stated in the service checklist apply to normal duty use. More demanding conditions (dust, temperature) require more regular lubrication.

The prescribed chain spray must be used in accordance with the instructions. Applying grease externally will not provide sufficient lubrication.



### **5.3 Servicing and inspection**

Thorough and expert servicing is one of the most important requirements for the safe operation of the industrial truck. Failure to perform regular servicing can lead to truck failure and poses a potential hazard to personnel and equipment.

The service intervals stated are based on single shift operation under normal operating conditions. They must be reduced accordingly if the truck is to be used in conditions of extreme dust, temperature fluctuations or multiple shifts.

The following maintenance checklist states the tasks and intervals after which they should be carried out. Maintenance intervals are defined as:

W = Every 50 service hours, at least weekly

A = Every 500 operating hours

B = Every 1000 operating hours, or at least annually

C = Every 2000 operating hours, or at least annually

W service intervals are to be performed by the customer.

In the run-in period - after approx. 100 service hours - or after repair work, the owner must check the wheel nuts/bolts and re-tighten if necessary.

### 5.3.1 Maintenance Checklist

		保养间隔				
		Standard = ★				
		Cold Store = ☆	W	A	B	C
Brake	1.1	Check magnetic brake air gap.			★	
Electrics	2.1	Test instruments, displays and control switches.			★	
	2.2	Test warning and safety device.	☆		★	
	2.3	Check fuse ratings.				★
	2.4	Make sure wire connections are secure and check for damage.			★	
	2.5	Test micro switch setting.			★	
	2.6	Check contactors			★	
	2.7	Frame leakage test			★	
	2.8	Test cable and motor attachments.			★	
	2.9	Check carbon brush wear, replace if necessary.			★	
Power supply	3.1	Visually inspect battery	☆		★	
	3.2	Check battery cable connections are secure, grease terminals if necessary.	☆		★	
	3.3	Check acid density, acid level and battery voltage.	☆		★	
Travel	4.1	Check motor suspension.			★	
	4.2	Check the transmission for noise and leakage.			★	
	4.3	Replace gear oil if service life exceeded (10,000 hours).				
	4.4	Check travel mechanism, adjust and lubricate if necessary. Check tiller recuperating function.	☆		★	
	4.5	Check wheels for wear and damage.	☆		★	
	4.6	Check wheel bearings and attachments.			★	

Truck design	5.1	Test the operator's platform and check for damage.			★	
	5.2	Check chassis for damage and screw connections.			★	
	5.3	Check labels.			★	
Hydraulic operation	6.1	Check operation, wear and setting.			★	
	6.2	Check forks for wear and damage.			★	
	6.3	Test hydraulic system.	☆		★	
	6.4	Check that hose and pipe lines and their connections are secure, check for leaks and damage.	☆		★	
	6.5	Check cylinders and piston rods for damage and leaks, and make sure they are secure.	☆		★	
	6.6	Check hydraulic oil level.	☆		★	
	6.7	Replace hydraulic oil filter.			☆	★
	6.8	Replace hydraulic oil.			☆	★
	6.9	Check wheels for wear and damage.			★	
Agreed performance levels	7.1	Lubricate truck in accordance with Lubrication Schedule.	☆		★	
	7.2	Test run			★	
	7.3	Demonstration after servicing			★	

### 5.3.2 Lubrication Schedule

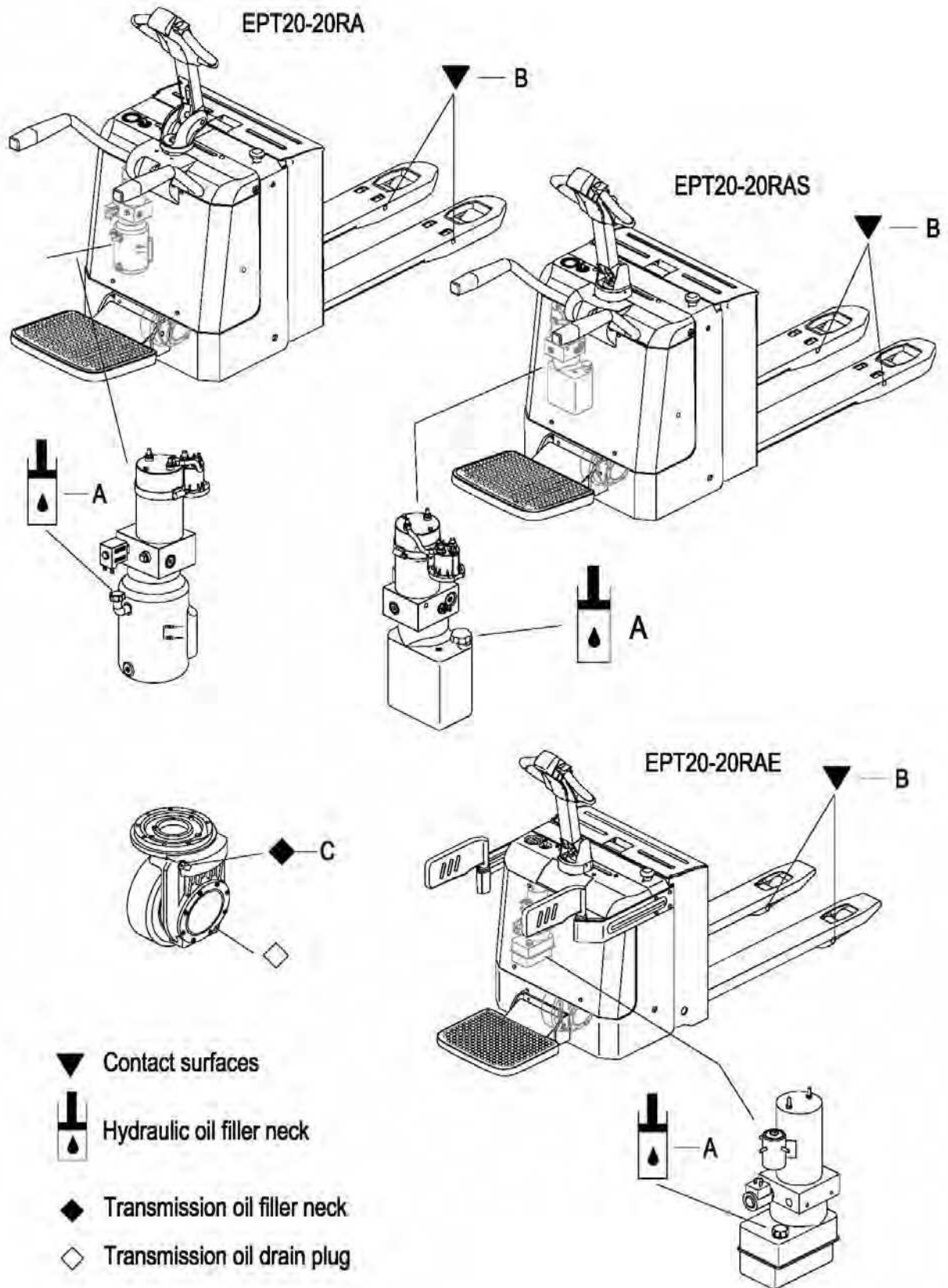

## Fuels, coolants and lubricants

**Handling consumables:** Consumables must always be handled correctly. Follow the manufacturer's instructions.

Improper handling is hazardous to health, life and the environment. Consumables must only be stored in appropriate containers. They may be flammable and must therefore not come into contact with hot components or naked flames.

Only use clean containers when filling up with consumables. Do not mix consumables of different grades. The only exception to this is when mixing is expressly stipulated in the Operating Instructions.

Avoid spillage. Spilled liquids must be removed immediately with suitable bonding agents and the bonding agent/consumable mixture must be disposed of in accordance with regulations.

Code	Description	Used for
A	HM46#	Hydraulic system
B	Grease, Polyube GA352P	Lubrication
C	GL-85W-90	Gear case

### 5.3.3 Maintenance Instructions

#### Prepare the truck for maintenance and repairs

All necessary safety measures must be taken to avoid accidents when carrying out maintenance and repairs. The following preparations must be made:

- Park the truck securely (See 3.2.4 Parking the truck securely Page 21 ).
- Draw back the emergency brake switch to prevent the truck from accidentally starting.
- When working under a raised lift truck, secure it to prevent it from tipping or sliding away.

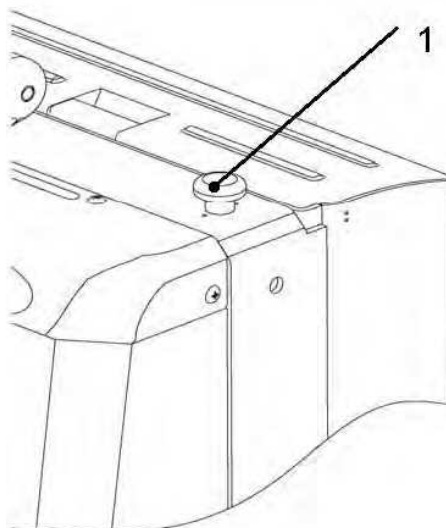

### Removing the front panel

Trucks with folding operator platform:

- Fold down the operator platform (1).
- Remove the four screws (2).
- Lift off the panel (3) and place it next to the truck.

When the work is finished, closed the panel (3).

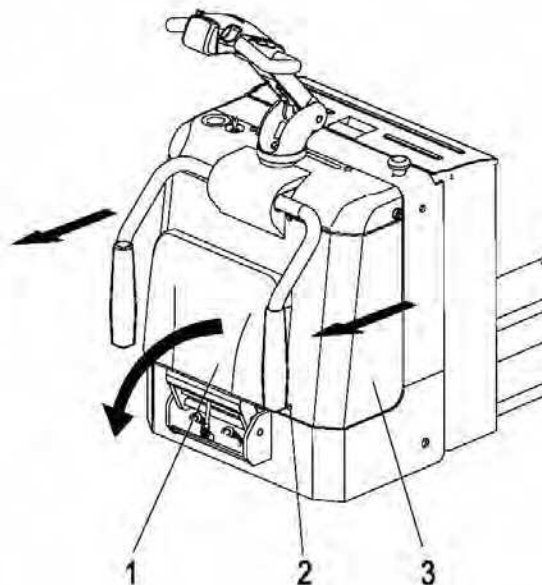

### Replacing the drive wheel

The drive wheel must only be replaced by authorised service personnel.

### Checking the hydraulic oil level

- Prepare the truck for maintenance and repairs (see section 6.1).
- Opening the front panel (see Section 6.3).
- Check hydraulic oil level in hydraulic reservoir .

If necessary, add hydraulic oil of the correct grade up . (for hydraulic oil specification, see Section 5).

### Check transmission oil level

- Prepare the truck for maintenance and repairs (See 5.3.3 Maintenance Instructions Page32).
  - Remove the front panel .
  - Turn the control handle to the right limited position.
  - Check the transmission oil level, it should be at the control plug level (See 5.3.2 Lubrication Schedule Page31).
  - If necessary add transmission oil of the correct grade .
- Installation is the reverse order.

#### **Warning!**

Forbid adding transmission oil within impurity.

### Checking electrical fuses

- Prepare the truck for maintenance and repairs (See 5.3.3 Maintenance Instructions Page32 ).
- Dismantle the front panel.
- Check rating of all fuses in accordance with table, replace if necessary.

Item	To protect:	Rating
1	Traction / Lift motor Fuse	200A
2	Controller Fuse	10A

### Recommissioning

The truck may only be recommissioned after cleaning or repair work, once the following operations have been performed.

- Test horn.
- Test Emergency brake switch.
- Test brake.
- Lubricate the truck in accordance with the maintenance schedule.

## 5.4 Decommissioning the industrial truck

If the industrial truck is to be decommissioned for more than two months, e.g. for operational reasons, it must be parked in a frost-free and dry location and all necessary measures must be taken before, during and after decommissioning as described.

On decommissioning the truck must be jacked up so that all the wheels are clear of the ground. This is the only way of ensuring that the wheels and wheel bearings are not damaged.

If the truck is to be out of service for more than 6 months, further measures must be taken in consultation with the manufacturer's service department.

### 5.4.1 Prior to decommissioning

- Thoroughly clean the truck.
  - Check the brakes.
  - Check the hydraulic oil level and replenish as necessary (See 5.3.3 Maintenance Instructions Page 32).
  - Apply a thin layer of oil or grease to any non-painted mechanical components.
  - Lubricate the truck in accordance with the maintenance schedule (See 5.3.2 Lubrication Schedule P31).
  - Charge the battery (See 4.3 Charging the battery P23).
  - Disconnect the battery, clean it and apply grease to the terminals.
- In addition, follow the battery manufacturer's instructions.
- Spray all exposed electrical contacts with a suitable contact spray.

#### **Warning!**

Charge every month:

- Charge the battery.

Battery powered trucks:

The battery must be charged at regular intervals to avoid depletion of the battery through self-discharge. The sulfatisation would destroy the battery.

### 5.4.2 Restoring the truck to operation after decommissioning

- Thoroughly clean the truck.
- Lubricate the truck in accordance with the maintenance schedule (See 5.3.2 Lubrication Schedule P31).
- Clean the battery, grease the terminals and connect the battery.
- Charge the battery (See 4.3 Charging the battery P23).
- Check transmission oil for condensed water and replace if necessary.
- Check hydraulic oil for condensed water and replace if necessary.
- Start up the truck (see 3.2.2 Operate and run the truck P17).

If there are switching problems in the electrical system, apply contact spray to the exposed contacts and remove any oxide layers on the contacts of the operating controls by applying them repeatedly.

Perform several brake tests immediately after re-commissioning the truck.



## **5.5 Safety checks to be performed at regular intervals and following any unusual incidents**

Carry out a safety check in accordance with national regulations. EP has a special safety department with trained personnel to carry out such checks. The truck must be inspected at least annually (refer to national regulations) or after any unusual event by a qualified inspector. The inspector shall assess the condition of the truck from purely a safety viewpoint, without regard to operational or economic circumstances. The inspector shall be sufficiently instructed and experienced to be able to assess the condition of the truck and the effectiveness of the safety mechanisms based on the technical regulations and principles governing the inspection of pallet trucks.

A thorough test of the truck must be undertaken with regard to its technical condition from a safety aspect. The truck must also be examined for damage caused by possible improper use. A test report shall be provided. The test results must be kept for at least the next 2 inspections.

The owner is responsible for ensuring that faults are immediately rectified. A test plate is attached to the truck as proof that it has passed the safety inspection. This plate indicates the due date for the next inspection.

## **5.6 Final de-commissioning, disposal**

Final, proper decommissioning or disposal of the truck must be performed in accordance with the regulations of the country of application. In particular, regulations governing the disposal of batteries, fuels and electronic and electrical systems must be observed.

## 6. Troubleshooting

This chapter is designed to help the user identify and rectify basic faults or the results of incorrect operation. When locating a fault, proceed in the order shown in the table.

Fault	Possible cause	Action
Truck does not start.	<ul style="list-style-type: none"> <li>– Battery connector not connected</li> <li>– Key switch in “0” position</li> <li>– Battery charge too low</li> <li>– Faulty fuse</li> <li>– Truck in charge mode</li> </ul>	<ul style="list-style-type: none"> <li>– Check the battery connector and connect if necessary.</li> <li>– Set key switch to “I”</li> <li>– Check battery charge, charge battery if Necessary</li> <li>– Test fuses</li> <li>– Interrupt charging</li> </ul>
Load can not be lifted	<ul style="list-style-type: none"> <li>– Charge capacity below 20% / 40%</li> <li>– Hydraulic oil level too low</li> <li>– Excessive load</li> </ul>	<ul style="list-style-type: none"> <li>– Charging the battery</li> <li>– Check the hydraulic oil level</li> <li>– Note maximum capacity (see data plate)</li> </ul>

If the fault cannot be rectified after carrying out the remedial procedure, notify the manufacturer 's service department ,as any further troubleshooting can only be performed by specially trained and qualified service personnel.